

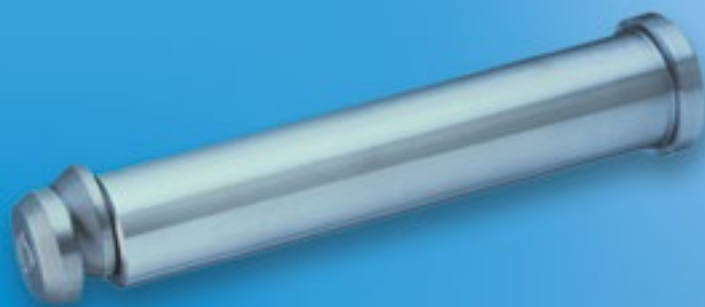

Use and maintenance manual complete of  
**EC** conformity declaration

# LIFTING PINS



Article numbers:  
**B02.100**

## INDEX

1. RISKS EVALUATION .....	3
2. SYMBOLS AND WARNINGS CLASSIFICATION .....	3
3. USE .....	4
4. HANDLING AND STORAGE .....	10
5. MAINTENANCE .....	10
EC CONFORMITY DECLARATION .....	11

## 1. RISKS EVALUATION

The matters of following pages refer to a classic use of lifting brackets and they can't forecast unspecified applications. For this reason each user must provide to his own risks evaluation and he must consider this manual as general reference support and as a summary of possible matters. To define the employ-procedures, to spread information and to check the compliance of these ones it's a duty and a responsibility of the user.

The lifting brackets have to be used as couplets for ropes and chains and they allow users to make on safety the following actions: LIFTING, HANDLING; the material, the production and the quality-check of all OMCR lifting pins comply with the Directive **2006/42/EC** requirements; all OMCR lifting elements have been tested with a static safety factor even to a minimum 1.5, all materials have been analyzed according to **UNI EN 10204**, samples of all materials have been subjected to tensile stress test according to **UNI EN 10002**. **Calculations and Risks valuations are in compliance with BMW, FCA, FORD, MERCEDES-BENZ, OPEL, PSA, RENAULT, VOLVO, VW-AUDI, VDI3366 norms.**







### **WARNING**

***Before using the lifting pins read this manual of use and maintenance with attention.***

***An improper or opposed use in reference to the prescriptions treated in this manual, deletes this EC conformity declaration and relieves OMCR from any responsibility.***

## 2. SYMBOLS AND WARNINGS CLASSIFICATION

According to ISO 3864-2, ANSI Z535.6, ANSI Z535.4 norms, in this manual are classified the following safety messages and symbols:

 <b>WARNING</b>	It indicates a hazardous situation which, if not avoided, could result in death or serious injury.
 <b>WARNING</b>	It indicates a hazardous situation which, if not avoided, could result in minor or moderate injury.
<b>NOTE</b>	It indicates advices on use or other especially helpful informations.
	It indicates general warning symbol.
	It indicates hazard of crushing consequent to an accidental fall or overturning of the load.
	It indicates hazard of crushing.
	It indicates musculoskeletal disorders for the handling of the loads.
	It indicates forbidden actions or uses.
	It indicates mandatory actions to avoid hazards.
	It indicates that it is forbidden to stop or to transit.

### 3. USE

#### 3.1

##### WARNING



Each lifting, handling or overturning operations must be executed by qualified and instructed worker; the lifting, handling or turnover' officers must use individual guard equipment.

#### 3.2

##### WARNING



Before each lifting, handling or overturning officers have to choose the most suitable sling to ensure a safe suspension with a correct load balance. A wrong sling method can modify the real capacity load of the ropes/chains and lifting accessories. In the following table you can verify the reduction of the nominal capacity load related to the sling angles in order to preserve the minimum safety factor.

##### NOTE

Refer to EN818-06 norm to define symmetric and asymmetric sling method: for asymmetric sling, the whole load should be supported by only two rope/chain wings.

#### 3.2.1 - LIFTING

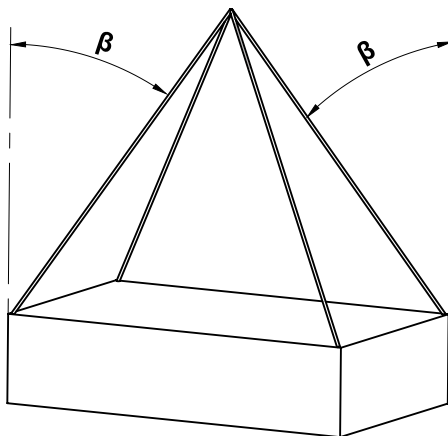

##### SYMMETRIC SLING EXAMPLE (RECOMMENDED CONDITION)

ANGLE	REDUCTION FACTOR OF THE NOMINAL CAPACITY LOAD
$0^\circ \leq \beta \leq 40^\circ$	1
$40^\circ < \beta \leq 50^\circ$	0.84
$50^\circ < \beta \leq 60^\circ$	0.65

**G** = Die load center

**β** = Rope angle from vertical

**NOTE:** lifting with  $\beta > 60^\circ$  is not provided

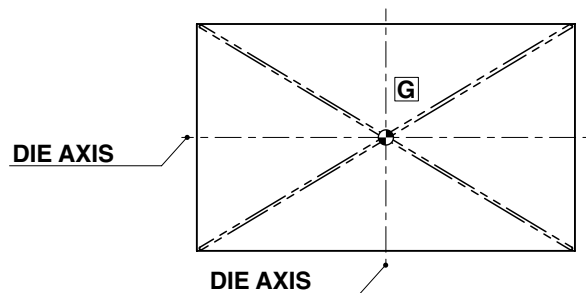

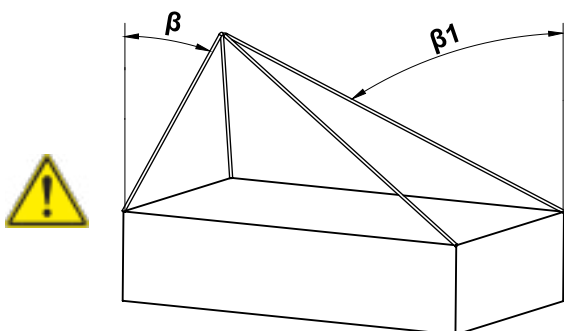

**ASYMMETRIC SLING EXAMPLE**  
( $\beta_1 > \beta$ )

**REDUCTION FACTOR OF THE NOMINAL CAPACITY LOAD**

0.5

**G** = Die load center

$\beta$  = Minimum rope angle from vertical

$\beta_1$  = Maximum rope angle from vertical

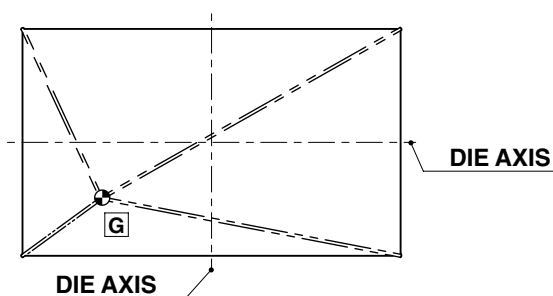

**WARNING**

*The missing respect of the prescriptions included in this manual may cause the accidental fall of the load.*

**3.2.2 - OVERTURNING**

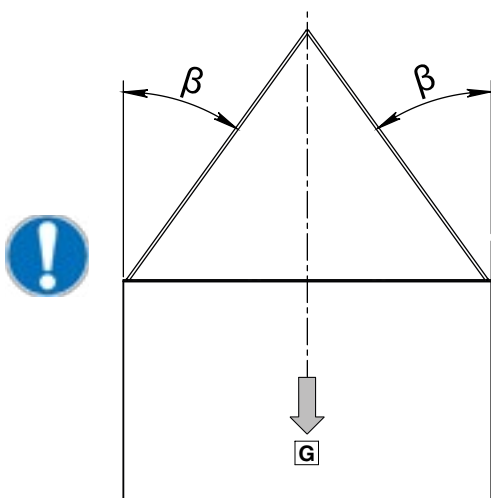

**SYMMETRIC SLING EXAMPLE**  
**(RECOMMENDED CONDITION)**

ANGLE	REDUCTION FACTOR OF THE NOMINAL CAPACITY LOAD
$0^\circ \leq \beta \leq 40^\circ$	1
$40^\circ < \beta \leq 50^\circ$	0.84
$50^\circ < \beta \leq 60^\circ$	0.65

**G** = Die load center

$\beta$  = Rope angle from vertical

**NOTE:** *overturning with  $\beta > 60^\circ$  is not provided*

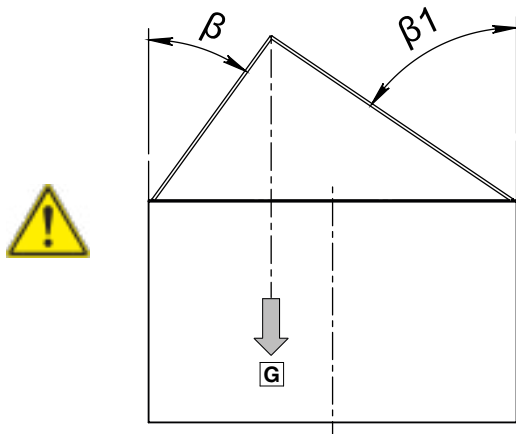

**ASYMMETRIC SLING EXAMPLE**  
( $\beta_1 > \beta$ )

ANGLE	REDUCTION FACTOR OF THE NOMINAL CAPACITY LOAD
$\beta < 15^\circ$	0.5
$\beta > 40^\circ$	
$\beta_1 - \beta > 15^\circ$	

**G** = Die load center

**$\beta$**  = Minimum rope angle from vertical

**$\beta_1$**  = Maximum rope angle from vertical

**⚠ WARNING**

*The missing respect of the prescriptions included in this manual may cause the accidental fall of the load.*

**3.2.3**

**⚠ WARNING**



*The die overturning is allowed only parallel with lifting pin axis.*

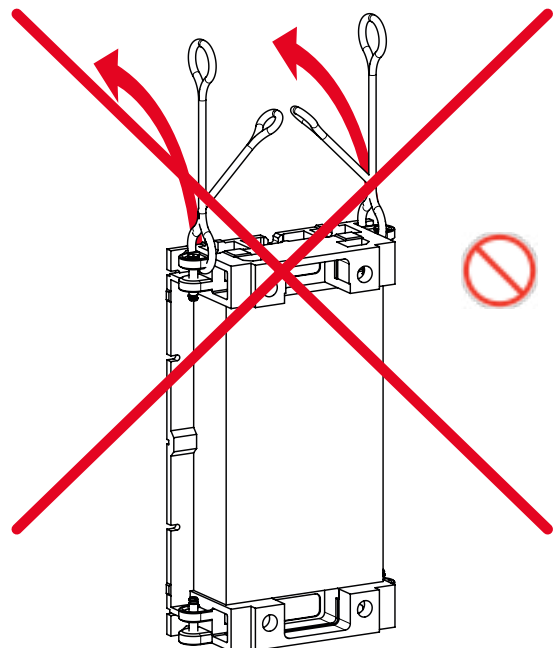
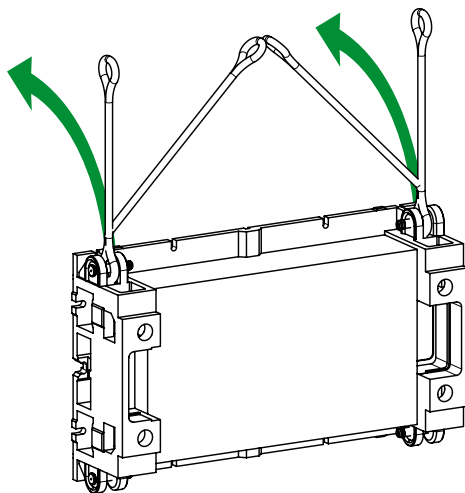

### 3.3

#### **⚠ WARNING**



Before each lifting, handling or turnover check that the lifting pin capacity load is in compliance with the die weight; the maximum capacity load, the work order number, the constructor label and the **EC conformity mark** are indelibly marked on the lifting pins (see **Pic.1**).

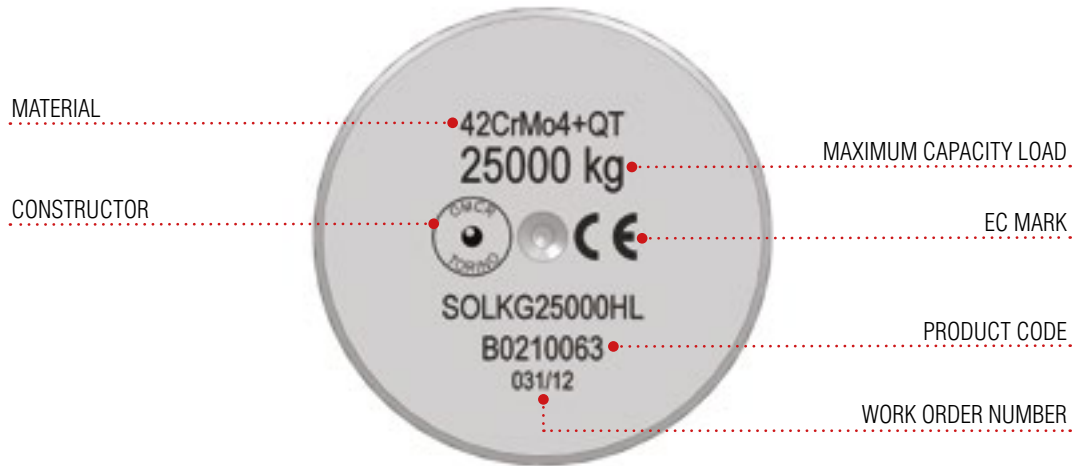

**Pic.1**

In case of lifting and handling, the lifting pin capacity load should be at least **1/2** of the whole die weight (upper half-die + lower half-die).

Example: die weight 25.000 kg - minimum lifting pin capacity load:  $25.000 / 2 = 12.500$  kg

In case of half-die overturning the lifting pin capacity load should be at least **1/2** of the half-die weight.

Example: Half-die weight 12.500 kg - minimum lifting pin capacity load:  $12.500 / 2 = 6.250$  kg

### 3.4

#### **⚠ WARNING**



Before each lifting, handling or overturning of the die, check that the chosen sling system (rope/chain, hook, etc.) doesn't present any defect or deformation to make it unsafe; **otherwise replace immediately the damaged parts.**

### 3.5

#### **WARNING**



Before each lifting, handling or overturning of the die be sure about the correct insertion of the lifting pin that has to be **ABSOLUTELY** assembled **with the safety ring** positioned in direction of the die axis: after inserting it, be sure that the **safety ring** is misaligned in reference to the hole so that the pin accidental extraction is avoided; check the movement of the **safety ring** by verifying the eccentricity "E" in reference to the pin (see **Pic.2**).

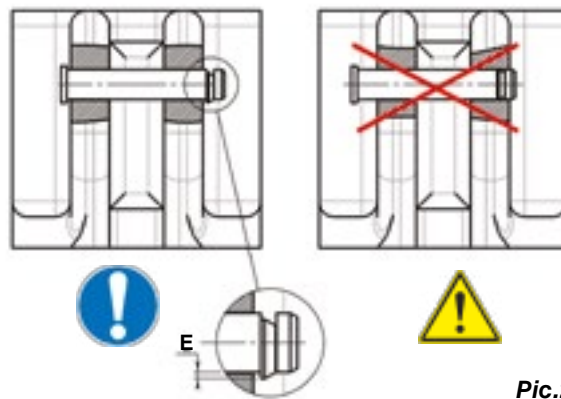

**Pic.2**

### 3.6

#### **WARNING**



It is recommended to provide barriers to avoid the wrong pins insertion (see **Pic.3**).

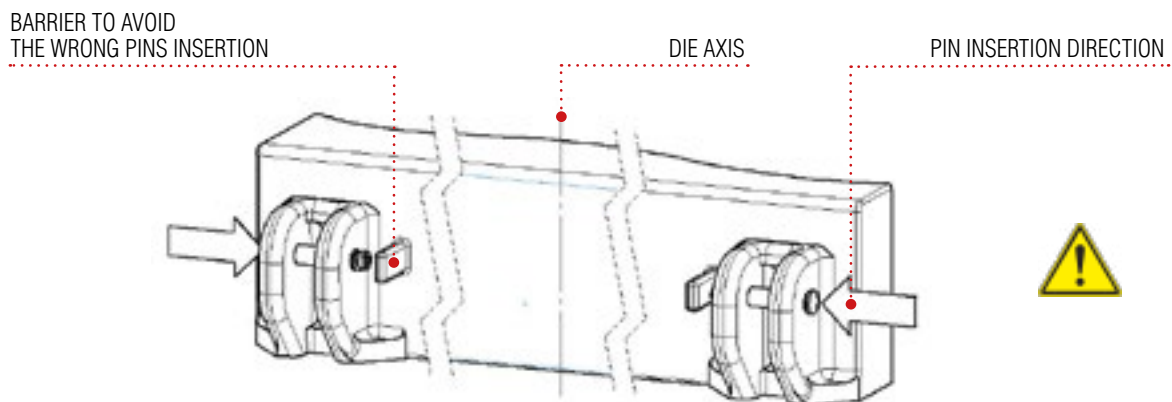

**Pic.3**



3.8

**⚠ WARNING**



To prevent the pin accidental extraction, don't make lifting, handling or overturning with sling angle bigger than 90° from the horizontal level (see **Pic.4**).

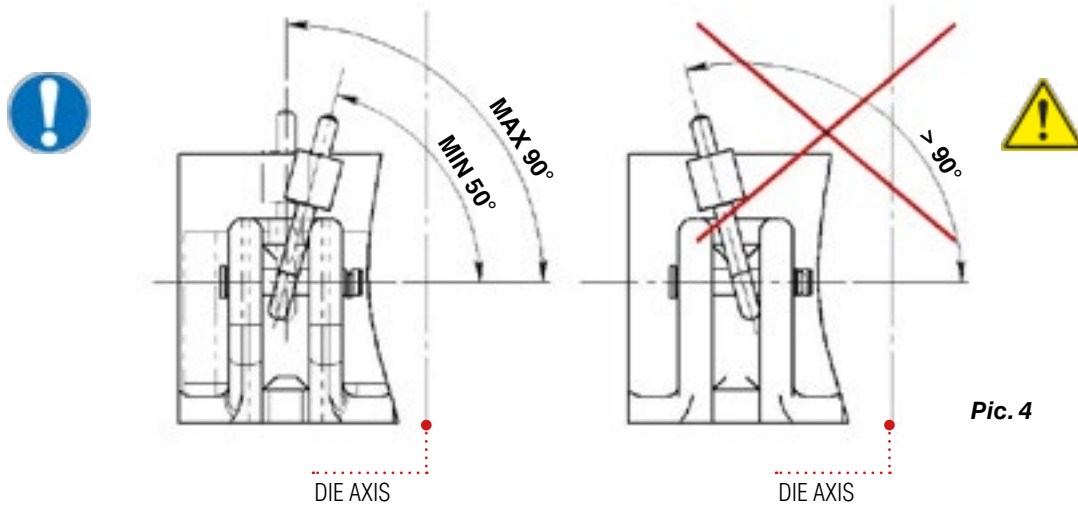

Pic. 4

3.9

**⚠ WARNING**



Before each lifting, handling or overturning of the die be sure that:

- the ropes / chains are secured in correct way;
- the ropes / chains are not in contact with cutting edge;
- the ropes / chains are not hooked to the die corners.

3.10

**⚠ WARNING**



Don't stand or transit nearby the load during lifting, handling or overturning operations (see **Pic.5**).



Fig.5

## 4. HANDLING AND STORAGE

- 4.1** All OMCR lifting pins have a unit weight lower than 15 kg and they can be moved by hand.
- 4.2** If not used the lifting pins must be stored far from wet and preserved from oxidation by applying protective oil.

## 5. MAINTENANCE

- 5.1** Once every 6 months check the presence of anomalies or oxidations by visual tests: in that case restore or replace the lifting pins.
- 5.2** Once every 12 months check the cilindricity of the pins to notice eventual permanent deformations (see **Pic.6**): in case of deformation over 0,25 mm replace the pins.
- 5.3** In case of unexpected failure of lifting ropes/chains with a consequent overload on the lifting pins, check their cilindricity (see **Pic.6**) to notice eventual deformations; in case of deformation over 0,25 mm replace the pins.
- 5.4** In case of accidental impacts on the lifting elements during the lifting, handling and overturning operations, check the cilindricity of the pins (see **Pic.6**); in case of deformation over 0,25 mm replace the pins.



**Pic.6**

# EC CONFORMITY DECLARATION

(Directive 2006/42/CE)

OMCR S.r.l. seated in Via Quarantelli, 8 – 10077 S.Maurizio C.se – (Torino-Italy) through its legal representative manager, declares that:

## **LIFTING PIN**

### **OMCR articles: B02.100**

Have a work order number indelibly marked on every model, it is possible to find out the documents filed in the Technical Office, to identify each manufacturing and inspective feature of the product. All the quality and safety procedures are arranged by Mr. Bertorello, responsible of the “technical file,” acting in OMCR, Via Quarantelli 8, 10077 San Maurizio C.se. These procedures have been exactly issued to allow OMCR mark with **EC symbol** to ensure that these products:



- *are in compliance with the established conditions from Directive 2006/42/EC of 9.6.2006*
- *are tested and controlled, to be suitable also with the harmonized and national UNI Norms, the European Directives and the Italian safety dispositions on work.*

*Before using lifting pins and lifting brackets, please read carefully the “Use and maintenance manual”.*

*An improper or opposed use in reference to the prescriptions treated in this manual, deletes this **EC conformity** declaration and relieves OMCR from any responsibility.*

*Translation of the original Use and Maintenance Manual and Conformity Declaration.*

*In case of doubts or misunderstandings, the Italian version is decisive.*

**OMCR S.r.l.**  
*Il legale rappresentante*  
**Domenico Zentilin**



Manuale di Uso e Manutenzione  
completo di dichiarazione **CE** di conformità.

# PERNI DI SOLLEVAMENTO

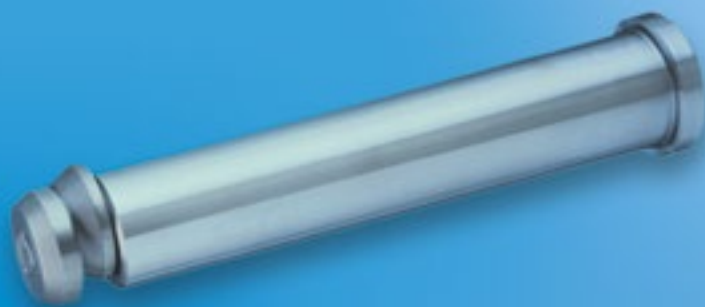

Codice Articolo:  
**B02.100**

## INDICE

1. VALUTAZIONE DEI RISCHI .....	14
2. SIMBOLOGIE E CLASSIFICAZIONE DELLE AVVERTENZE .....	14
3. USO .....	15
4. MOVIMENTAZIONE E STOCCAGGIO .....	21
5. MANUTENZIONE .....	21
DICHIARAZIONE CE DI CONFORMITÀ .....	22

## 1. VALUTAZIONE DEI RISCHI

I contenuti delle pagine che seguono sono riferiti agli usi classici dei perni di sollevamento e non possono prevedere impieghi non specifici. Per tale ragione ciascun utilizzatore deve provvedere ad una propria valutazione dei rischi e tenere conto di questo manuale come supporto di riferimento generale considerando la necessità di sintesi nel trattare gli argomenti. Rimane compito e responsabilità dell'utilizzatore definire per gli addetti le procedure di impiego per le operazioni da eseguire, darne informazione e verificarne l'osservanza.









I perni di sollevamento servono da aggancio per funi o catene e permettono di effettuare in sicurezza operazioni di: SOLLEVAMENTO e MOVIMENTAZIONE; il materiale, la produzione e il collaudo di tutti gli elementi di sollevamento **OMCR** sono conformi alle richieste della **direttiva 2006/42/CE**; tutti gli elementi di sollevamento **OMCR** sono verificati con un coefficiente di prova statica pari a minimo 1.5, su tutti i materiali sono effettuate analisi secondo la UNI EN 10204, a campione vengono effettuate prove a trazione convenzionale conformi alla UNI EN 10002. **I calcoli e le valutazioni dei rischi sono stati fatti in conformità alle normative di BMW, FCA, FORD, MERCEDES-BENZ, OPEL, PSA, RENAULT, VOLVO, VW-AUDI, VDI3366.**

### **AVVERTENZA**

**Prima dell'utilizzo dei perni di sollevamento leggere attentamente il presente manuale di uso e manutenzione. Un uso improprio o contrario, a quanto prescritto nel presente manuale, solleva l'OMCR da ogni responsabilità in merito alla sicurezza degli elementi citati.**

## 2. SIMBOLOGIE E CLASSIFICAZIONE DELLE AVVERTENZE

Secondo le normative ISO 3864-2, ANSI Z535.6, ANSI Z535.4, nel presente manuale sono stati classificati i seguenti messaggi di sicurezza e i simboli:

 <b>ATTENZIONE</b>	Indica una situazione potenzialmente pericolosa, che se non evitata, può provocare gravi infortuni o morte.
 <b>ATTENZIONE</b>	Indica una situazione potenzialmente pericolosa, che se non evitata, può provocare lesioni lievi o moderate
<b>NOTE</b>	Indica suggerimenti o altre informazioni di particolare importanza.
	Indica un pericolo generico.
	Indica un rischio di schiacciamento conseguente la caduta o il ribaltamento del carico.
	Indica un rischio di cesoiamento conseguente la caduta o il ribaltamento del carico.
	Indica un rischio muscolo-scheletrico per la movimentazione manuale dei carichi.
	Indica operazioni o modo d'uso proibiti.
	Indica azioni da effettuare per evitare rischi.
	Indica il divieto di sostare o transitare.

### 3. USO

#### 3.1

#### **AVVERTENZA**



Ogni operazione di sollevamento e movimentazione deve essere eseguita da personale qualificato ed opportunamente formato; gli addetti al sollevamento e movimentazione devono far uso dei mezzi di protezione individuale in loro dotazione.

#### 3.2

#### **AVVERTENZA**



Prima di ogni sollevamento o movimentazione gli addetti devono scegliere la modalità di imbracatura più idonea per garantire una sospensione sicura con un corretto equilibrio del carico. L'effettiva portata delle funi / catene e degli accessori di sollevamento può essere alterata da una imbracatura scorretta. Nelle tabelle seguenti si può valutare la riduzione della portata nominale in funzione dell'angolo dell'imbracatura al fine di mantenere costante il fattore di sicurezza.

#### NOTE

Per la definizione delle imbracature simmetriche e asimmetriche fare riferimento alla norma EN818-06: in caso di imbracature asimmetriche, si considera che il peso da sollevare sia sopportato da due soli bracci di fune/catena.

#### 3.2.1 - SOLLEVAMENTO

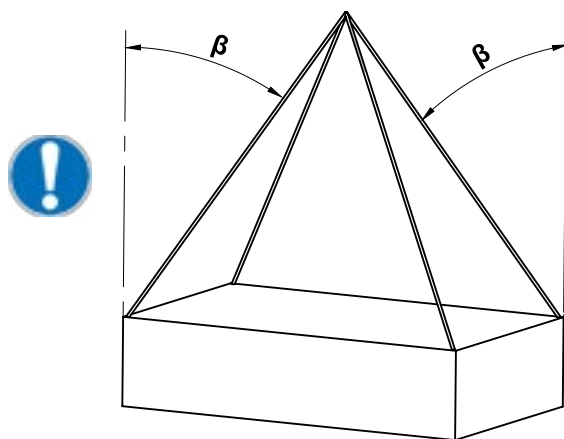

#### ESEMPIO DI IMBRACATURE SIMMETRICHE (CONDIZIONE CONSIGLIATA)

ANGOLO	FATTORE DI RIDUZIONE DELLA PORTATA DEL PERNO
$0^\circ \leq \beta \leq 40^\circ$	1
$40^\circ < \beta \leq 50^\circ$	0.84
$50^\circ < \beta \leq 60^\circ$	0.65

**G** = Baricentro stampo

**β** = Angolo funi dalla verticale

**NOTA:** non è previsto il sollevamento con  $\beta > 60^\circ$

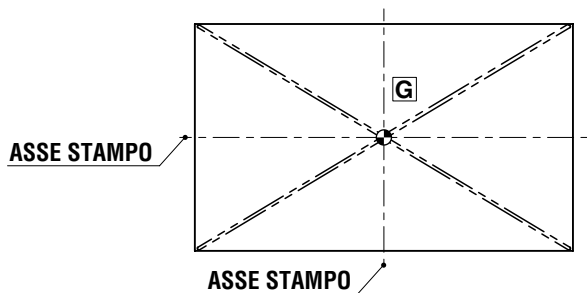

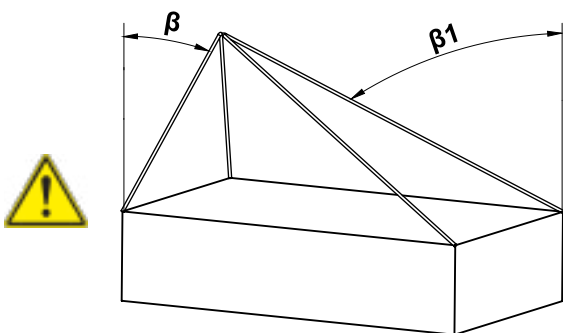

**ESEMPIO DI IMBRACATURE ASIMMETRICHE**

**FATTORE DI RIDUZIONE DELLA PORTATA DEL PERNO**

0.5

**G** = Baricentro stampo

**β** = Angolo funi minimo dalla verticale

**β1** = Angolo funi massimo dalla verticale

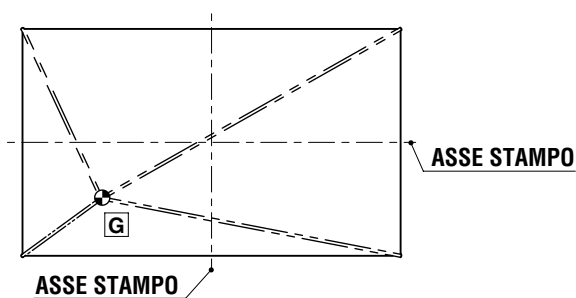

**AVVERTENZA**

*Il mancato rispetto delle prescrizioni contenute nel presente manuale può provocare il rischio di caduta accidentale del carico.*

**3.2.2 - RIBALTAMENTO**

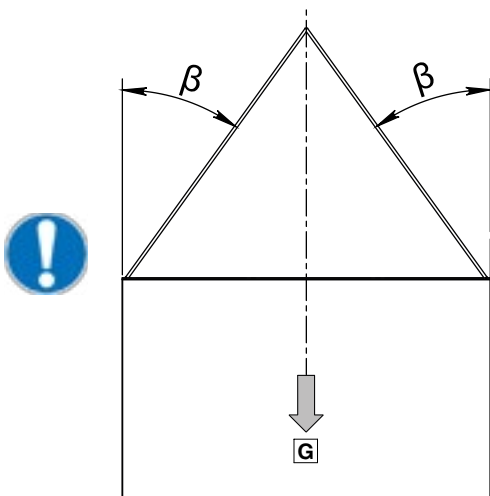

**ESEMPIO DI IMBRACATURE SIMMETRICHE (CONDIZIONE CONSIGLIATA)**

ANGOLO	FATTORE DI RIDUZIONE DELLA PORTATA DEL PERNO
$0^\circ \leq \beta \leq 40^\circ$	1
$40^\circ < \beta \leq 50^\circ$	0.84
$50^\circ < \beta \leq 60^\circ$	0.65

**G** = Baricentro stampo

**β** = Angolo funi dalla verticale

**NOTA:** non è previsto il ribaltamento con  $\beta > 60^\circ$



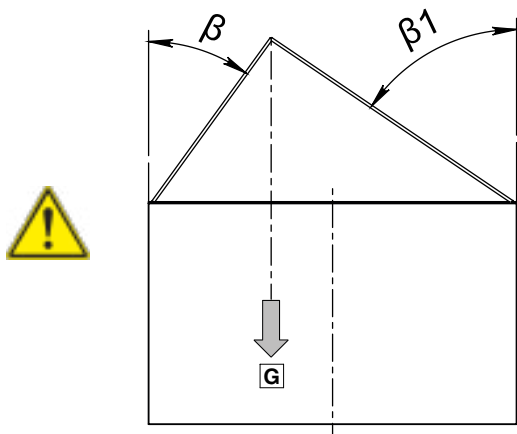

**ESEMPIO DI IMBRACATURE ASIMMETRICHE**  
( $\beta_1 > \beta$ )

ANGOLO	FATTORE DI RIDUZIONE DELLA PORTATA DEL PERNO
$\beta < 15^\circ$	0.5
$\beta > 40^\circ$	
$\beta_1 - \beta > 15^\circ$	

**G** = Baricentro stampo

**β** = Angolo funi minimo dalla verticale

**β1** = Angolo funi massimo dalla verticale

**⚠ AVVERTENZA**

*Il mancato rispetto delle prescrizioni contenute nel presente manuale può provocare il rischio di caduta accidentale del carico.*

**3.2.3**

**⚠ AVVERTENZA**



*Il ribaltamento dello stampo può essere eseguito solo parallelamente all'asse del perno di sollevamento*

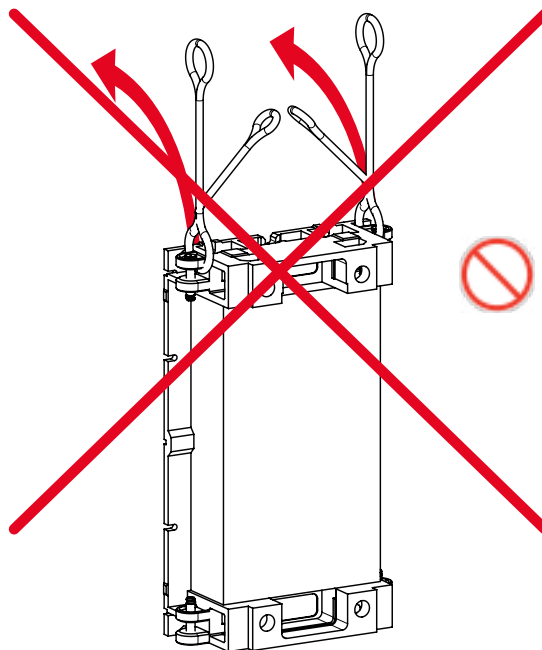
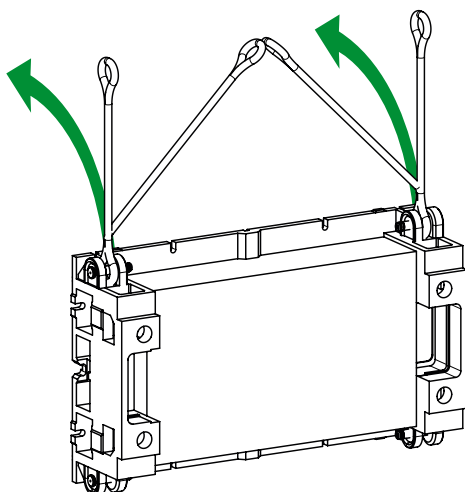

### 3.3

#### **AVVERTENZA**



Prima di ogni sollevamento, movimentazione o ribaltamento verificare che la portata dei perni di sollevamento sia conforme al peso dello stampo; la portata massima, la commessa di fabbricazione, il logo del costruttore, il marchio di conformità CE, il codice prodotto e il materiale sono marcati in modo indelebile sul perno di sollevamento (vedi **Fig.1**).

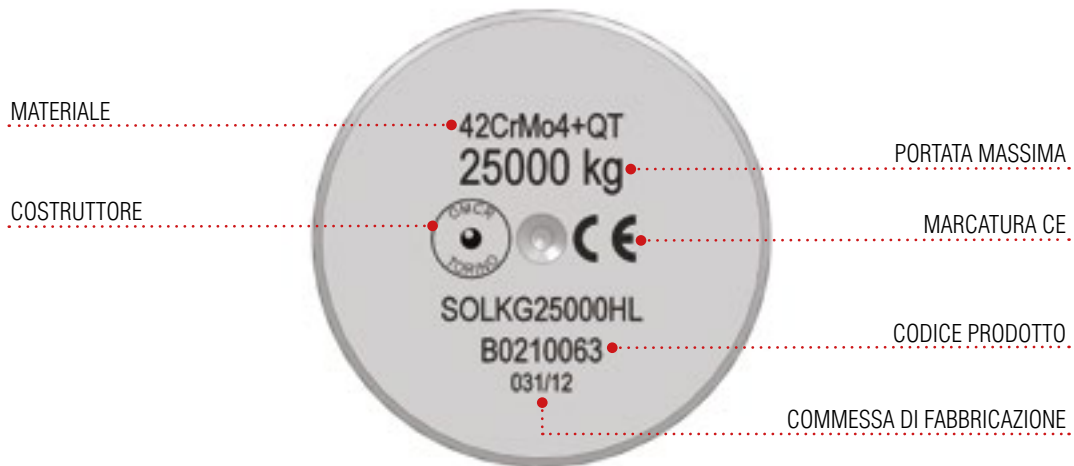

**Fig.1**

In caso di sollevamento e movimentazione la portata del perno di sollevamento deve essere pari ad almeno **1/2** del peso totale dello stampo (semistampo superiore + semistampo inferiore).

Es: peso stampo 25.000 kg - portata minima del perno:  $25.000 / 2 = 12.500$  kg

In caso di ribaltamento di un semistampo la portata del perno di sollevamento deve essere pari ad almeno **1/2** del peso del semistampo.

Es: peso semistampo 12.500 kg - portata minima del perno:  $12.500 / 2 = 6.250$  kg

### 3.4

#### **AVVERTENZA**



Prima di ogni sollevamento, movimentazione o ribaltamento dello stampo verificare che l'imbracatura scelta (fune / catena, ganci, redance, ecc.) non presenti difetti o malformazioni tali da pregiudicarne l'affidabilità; **nel caso sostituire immediatamente le parti difettose.**

### 3.5

#### **AVVERTENZA**



Prima di ogni sollevamento, movimentazione o ribaltamento dello stampo assicurarsi del corretto inserimento del perno di sollevamento che deve **TASSATIVAMENTE** essere montato con l'**anello di sicurezza** rivolto verso l'asse dello stampo: dopo averlo inserito accertarsi che l'**anello di sicurezza** sia disassato rispetto al foro e impedisca lo sfilamento del perno; verificare il movimento dell'**anello di sicurezza** verificando l'eccentricità "E" rispetto al perno (vedi Fig.2)

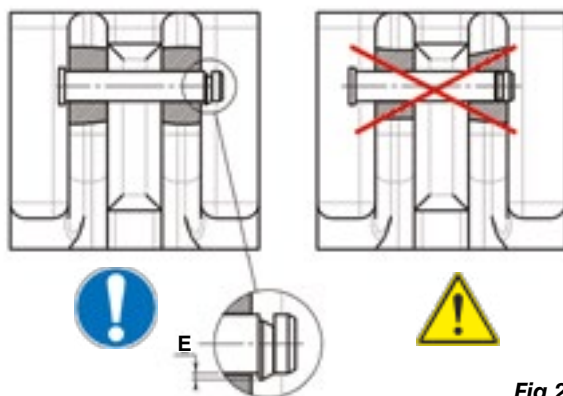

Fig.2

### 3.6

#### **AVVERTENZA**



Si consiglia l'uso di barriere per impedire l'inserimento scorretto dei perni (vedi Fig.3)

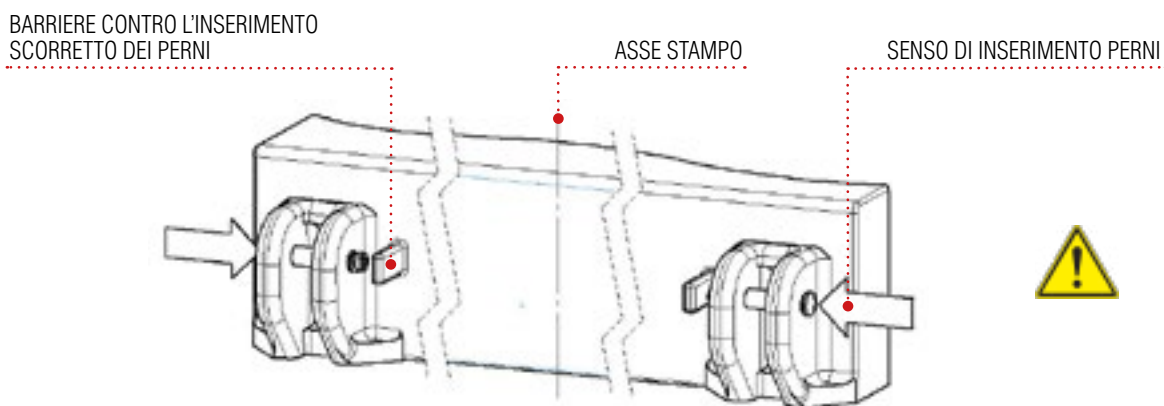

Fig.3

3.8

**AVVERTENZA**



Non effettuare sollevamento o movimentazione con imbracature che formino angoli superiori a 90° rispetto all'orizzontale, in caso contrario si può verificare lo sfilamento del perno con rischio di caduta del carico (vedi Fig.4).

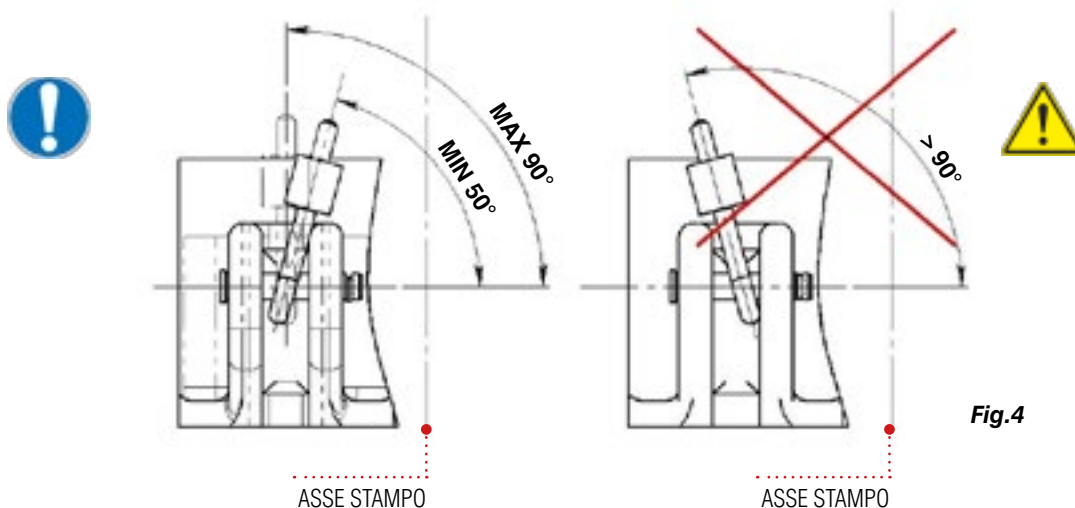

Fig.4

3.9

**AVVERTENZA**



Prima di ogni sollevamento o movimentazione dello stampo verificare che:

- le funi / catene siano assicurate in modo corretto;
- le funi / catene non siano a contatto di bordi taglienti;
- le funi / catene non siano agganciate in spigoli dello stampo.

3.10

**AVVERTENZA**



Non sostare o transitare nelle vicinanze del carico durante le operazioni di sollevamento, movimentazione o ribaltamento (vedi Fig.5).



Fig.5

## 4. MOVIMENTAZIONE E STOCCAGGIO

**4.1** Tutti i perni di sollevamento OMCR sono di peso unitario inferiore ai 15 kg e possono essere movimentati a mano.

**4.2** I perni di sollevamento, se non utilizzati, devono essere stoccati in luogo riparato dall'umidità e protetti dall'ossidazione applicando olio protettivo.

## 5. MANUTENZIONE

**5.1** Effettuare ogni 6 mesi controlli visivi per verificare la presenza di anomalie visibili o insorgenze di ossidazione: nel caso ripristinare o sostituire i perni interessate.

**5.2** Effettuare almeno ogni 12 mesi un controllo di cilindricità sui perni per verificare eventuali deformazioni permanenti (**Fig.6**): nel caso di errori superiori a 0,25 mm sostituire i perni interessati.

**5.3** In caso di cedimenti improvvisi di funi / catene di sollevamento con conseguente sovraccarico sui perni di sollevamento, sottoporre questi a controllo di cilindricità (vedi **Fig.6**) per verificare eventuali deformazioni, permanententi; nel caso di errori superiori a 0,25 mm sostituire i perni interessati.

**5.4** In caso di urti accidentali nelle zone di imbracatura durante le operazioni di sollevamento, movimentazione o ribaltamento, sottoporre i perni di sollevamento a controllo di cilindricità per verificare eventuali deformazioni; nel caso di errori superiori a 0,25 mm (vedi **Fig.6**) sostituire i perni interessati.



**Fig.6**

# DICHIARAZIONE CE DI CONFORMITÀ

(Direttiva Macchine 2006/42/CE)

L' OMCR S.r.l. con sede in Via Quarantelli, 8 – 10077 S.Maurizio C.se – (Torino-Italia) nella persona del suo legale rappresentante, dichiara che, i:

## PERNI DI SOLLEVAMENTO

### Codice articolo: B02.100

hanno un numero di commessa di fabbricazione marcato in modo indelebile su ogni singolo esemplare, dal quale in ogni momento, si può risalire alla documentazione archiviata presso l'Ufficio Tecnico e così identificare ogni caratteristica ed elemento di produzione e collaudo.

Tutte le procedure di qualità e sicurezza predisposte dal Sig. Bertorello, responsabile del "Fascicolo tecnico", operante nella sede dell'OMCR, in Via Quarantelli, 8 10077 San Maurizio C.se, sono state correttamente eseguite e ciò ha permesso la stampigliatura del simbolo **CE** per garantire che tali particolari:



- sono conformi alle condizioni stabilite dalla Direttiva Macchine 2006/42/CE del 9.6.2006
- sono stati oggetto di controlli e verifiche per ritenere tali prodotti conformi anche per le norme UNI armonizzate e nazionali, le direttive Europee e le disposizioni italiane sulla sicurezza del lavoro

*Prima dell'utilizzo dei perni di sollevamento leggere attentamente il manuale di uso e manutenzione.*

*Un uso improprio o contrario, a quanto prescritto nel manuale, rende nulla la validità della presente dichiarazione CE di conformità e solleva l'OMCR da ogni responsabilità in merito.*

**OMCR S.r.l.**

*Il legale rappresentante*

*Domenico Zentilin*



Betriebs- und Instandhaltungsanleitung  
mit CE-Konformitätserklärung

# TRAGBOLZEN MIT FALLRINGSICHERUNG

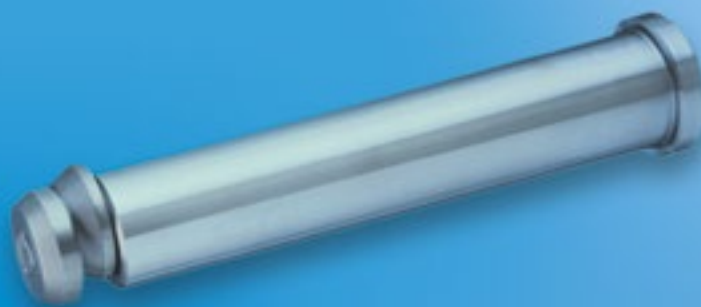

Artikelnummern:

**B02.100**

## INHALTSVERZEICHNIS

1. RISIKOBEURTEILUNG .....	.25
2. ZEICHENERKLÄRUNG .....	.25
3. ANWENDUNG .....	.26
4. TRANSPORT UND LAGERUNG .....	.32
5. INSTANDHALTUNG .....	.32
CE-Konformitätserklärung .....	.33



## 1. RISIKOBEURTEILUNG

Der Inhalt der folgenden Seiten bezieht sich auf die klassische Anwendung der Tragbolzen und kann unspezifische Anwendungen nicht vorhersehen. Aus diesem Grund muss jeder Anwender eine eigene Risikobeurteilung vornehmen und diese Betriebsanleitung als allgemeine Richtlinie berücksichtigen, unter Berücksichtigung der Notwendigkeit der Synthese bei der Abhandlung der Argumente. Es bleibt die Aufgabe des Anwenders, unter seiner Verantwortung, die Anwendungsverfahren zur Durchführung der Arbeitsgänge für die Mitarbeiter zu definieren, darüber zu informieren und deren Einhaltung zu überprüfen.



Die Tragbolzen dienen als Haken für Seile oder Ketten und gestatten eine sichere Durchführung folgender Arbeitsgänge: HEBEN und BEWEGEN. Das Material, die Herstellung und die Kontrolle aller **OMCR** Tragelemente entspricht den Anforderungen der Richtlinie **2006/42/EG**. Alle Tragelemente von **OMCR** sind mit einem statischen Prüfungskoeffizienten von mindestens 1,5 geprüft, an allen Materialien wurden Analysen gemäß **UNI EN 10204** durchgeführt, stichprobenmäßig werden konventionelle Zugprüfungen gemäß **UNI EN 10002** durchgeführt. **Die Berechnung und die Risikobeurteilung erfolgt gemäß der Normen von BMW, FCA, FORD, MERCEDES-BENZ, OPEL, PSA, RENAULT, VOLVO, VW-AUDI und der Richtlinie VDI3366.**

### **WARNUNG**

***Vor dem Einsatz der Tragbolzen die Betriebs- und Instandhaltungsanleitung aufmerksam lesen. Ein unsachgemäße oder gegenteilige Anwendung ggü. den in dieser Betriebsanleitung beschriebenen Punkten enthebt OMCR von jeglicher Verantwortung hinsichtlich der Sicherheit der hier zitierten Elemente.***

## 2. ZEICHENERKLÄRUNG

Die folgenden Sicherheitshinweise und Symbole der vorliegenden Betriebs- und Instandhaltungsanleitung sind gemäß den Normen ISO 3864-2 und ANSI Z535.6 klassifiziert worden:

 <b>WARNUNG</b>	Zeigt eine potentiell gefährliche Situation an, die, wenn sie nicht vermieden wird, zu schweren Unfälle oder zum Tod führen kann.
 <b>VORSICHT</b>	Zeigt eine potentiell gefährliche Situation an, die, wenn sie nicht vermieden wird, zu leichten bis mittelschweren Verletzungen führen kann.
<b>ANMERKUNG</b>	Weist auf Anregungen oder andere Informationen von besonderer Wichtigkeit hin.
	Allgemeine Gefahr.
	Quetschgefahr mit daraus folgendem Fallen oder Umkippen der Ladung.
	Schergefahr mit daraus folgendem Fallen oder Umkippen der Ladung.
	mögliche gefährdung des Bewegungsapparates beim manuellen Handling von Lasten
	Verbotene Tätigkeit bzw. Anwendungsart.
	Tätigkeiten, die auszuführen sind, um Risiken zu vermeiden.
	Es ist verboten sich aufzuhalten oder durchzugehen.

### 3. ANWENDUNG

#### 3.1

##### ⚠️ WARNUNG



Jedes Heben / Bewegen muss von qualifiziertem und entsprechend ausgebildetem Personal ausgeführt werden. Den für das Heben / Bewegen zuständigen Personen müssen individuelle Schutzeinrichtungen zur Verfügung gestellt werden, die sie verwenden müssen.

#### 3.2

##### ⚠️ WARNUNG



Vor jedem Heben/Bewegen müssen die hierfür Zuständigen die am besten geeignete Anschlagart wählen, um eine sicheres Aufhängen mit einem korrekten Gleichgewicht der Ladung zu gewährleisten. Die effektive Tragkraft der Seile/Ketten und des Hebezubehörs kann durch eine nicht korrekte Anschlagart verändert werden. In der folgenden Tabelle kann man die Reduzierung der Nominaltragkraft in Funktion des Neigungswinkels beurteilen, um den Sicherheitsfaktor konstant zu halten.

##### ANMERKUNG

Zur Definition des symmetrischen oder asymmetrischen Anschlags siehe Norm EN 818-06: Im Falle eines asymmetrischen Anschlags wird angenommen, dass das zu hebende Gewicht nur von zwei Strängen des Seils bzw. der Kette getragen wird.

#### 3.2.1 - HEBEN

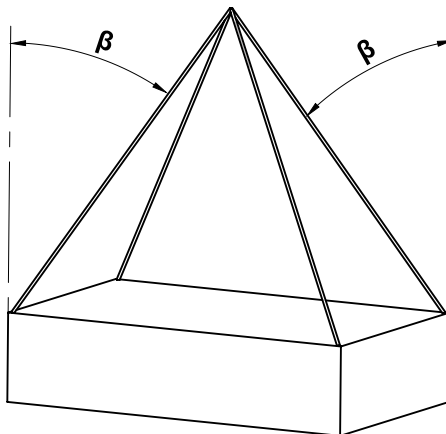

##### Beispiel: SYMMETRISCHER ANSCHLAG (empfohlen)

Neigungswinkel	Reduktionsfaktor der Nominaltragkraft des Tragbolzens
$0^\circ \leq \beta \leq 40^\circ$	1
$40^\circ < \beta \leq 50^\circ$	0.84
$50^\circ < \beta \leq 60^\circ$	0.65

**G** = Schwerpunkt Werkzeug

**β** = Neigungswinkel

**Anmerkung:** Das Heben mit  $\beta > 60^\circ$  ist nicht vorgesehen

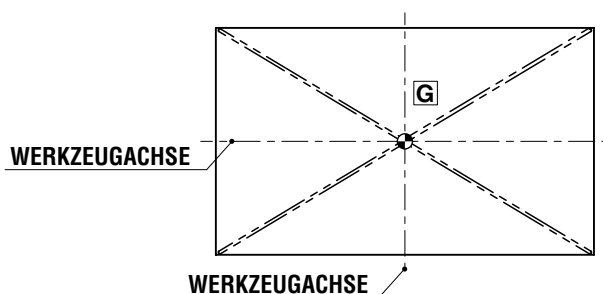

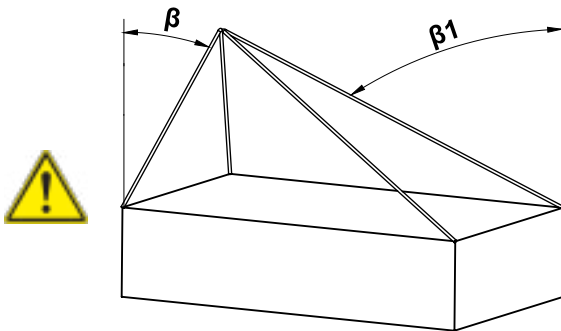

**Beispiel: ASYMMETRISCHER ANSCHLAG**

**Reduktionsfaktor der Nominaltragkraft des Tragbolzens**

0.5

**G** = Schwerpunkt Werkzeug

$\beta$  = min. Neigungswinkel

$\beta1$  = max. Neigungswinkel

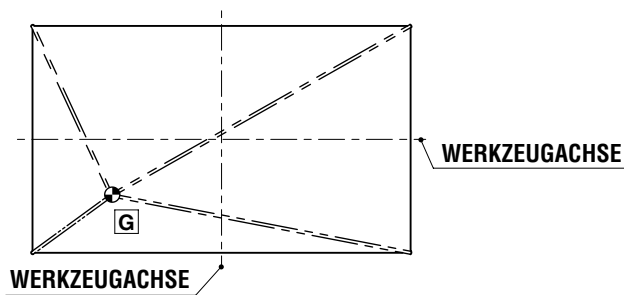

**! WARNUNG**

Das Nichtbeachten der in dieser Anleitung enthaltenen Vorschriften kann ein Herabfallen der Ladung hervorrufen.

**3.2.2 - WENDEN**

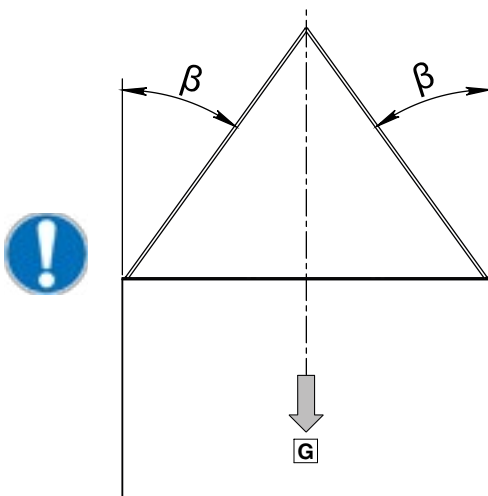

**Beispiel: SYMMETRISCHER ANSCHLAG (empfohlen)**

Neigungswinkel	Reduktionsfaktor der Nominaltragkraft des Tragbolzens
$0^\circ \leq \beta \leq 40^\circ$	1
$40^\circ < \beta \leq 50^\circ$	0.84
$50^\circ < \beta \leq 60^\circ$	0.65

**G** = Schwerpunkt Werkzeug

$\beta$  = Neigungswinkel

**Anmerkung:** Das Wenden mit  $\beta > 60^\circ$  ist nicht vorgesehen

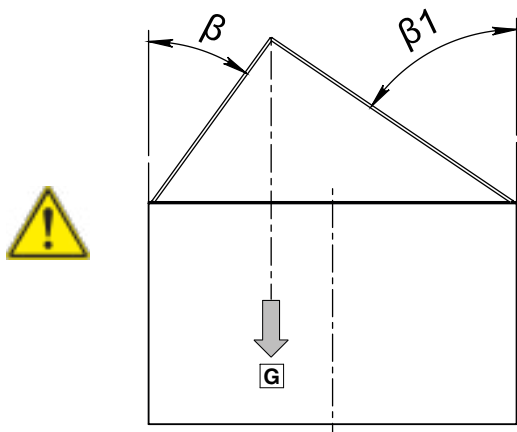

**Beispiel: ASYMMETRISCHER ANSCHLAG**  
( $\beta_1 > \beta$ )

Neigungswinkel	Reduktionsfaktor der Nominaltragkraft des Tragbolzens
$\beta < 15^\circ$	0.5
$\beta > 40^\circ$	
$\beta_1 - \beta > 15^\circ$	

**G** = Schwerpunkt Werkzeug

**β** = min. Neigungswinkel

**β1** = max. Neigungswinkel

**⚠️ WARNUNG**

Das Nichtbeachten der in dieser Anleitung enthaltenen Vorschriften kann ein Herabfallen der Ladung hervorrufen.

**3.2.3**

**⚠️ WARNUNG**



Das Wenden des Werkzeugs kann nur parallel zu den Achsen des Tragbolzens erfolgen.

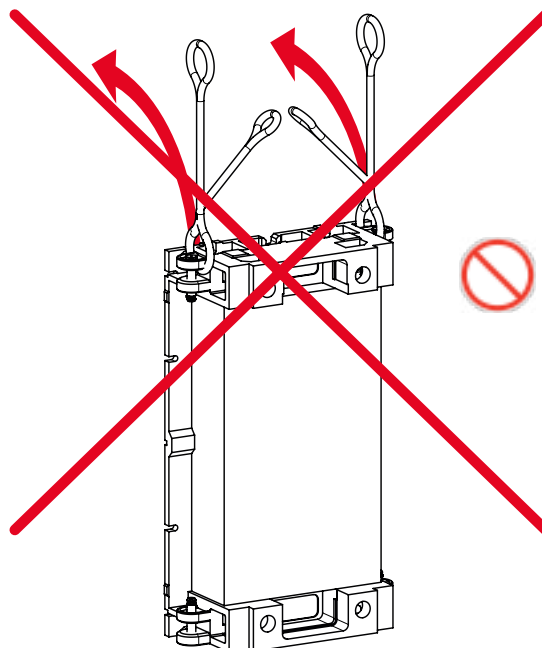
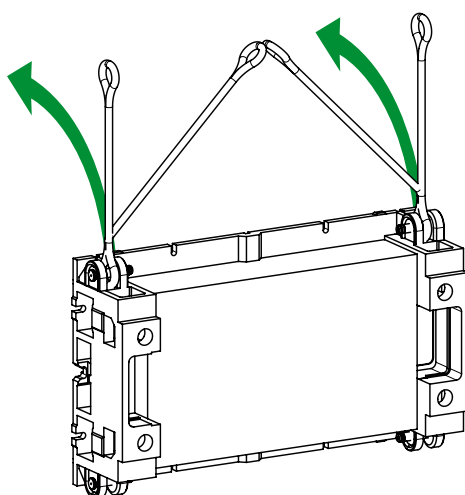

### 3.3

#### **⚠️ WARNUNG**



Vor jedem Heben / Bewegen / Wenden prüfen, dass die Tragkraft der Tragbolzen gemäß dem Werkzeuggewicht ist (**ausgewiesen auf entsprechendem Schild**). Die maximale Tragkraft, das Produktionslos, das Herstellerlogo, das CE-Zeichen, die Art.-Nr. und das Material sind unauslöschlich auf Tragbolzen markiert (siehe **Fig.1**).

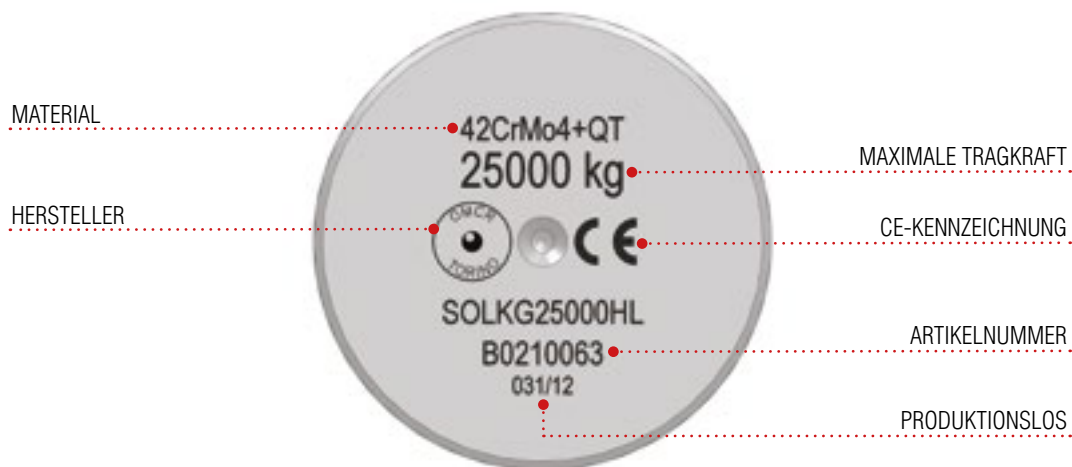

**Fig.1**

Beim Heben und Bewegen muss die Tragkraft der Tragbolzen mindestens gleich der **Hälfte** des Gesamtgewichts des Werkzeugs sein (oberen Werkzeughälfte + untere Werkzeughälfte).

Beispiel: Gewicht Werkzeug 25.000 kg - Mindesttragkraft der Tragbolzen:  $25.000 / 2 = 12.500$  kg

Beim Wenden einer Werkzeughälfte muss die Tragkraft der Tragbolzen mindestens gleich der **Hälfte** des Gewichts der Werkzeughälfte sein.

Beispiel: Gewicht Werkzeughälfte 12.500 kg - Mindesttragkraft der Tragbolzen:  $12.500 / 2 = 6.250$  kg

### 3.4

#### **⚠️ WARNUNG**



Vor jedem Heben / Bewegen / Wenden des Werkzeugs prüfen, dass die gewählte Anschlagart (Seil/Kette, Haken, etc.) keinen Fehler oder Deformierungen aufweist, die sie unsicher machen. In diesem Fall **sofort die defekten Teile entfernen**.

### 3.5

#### **⚠️ WARNUNG**



Vor jedem Heben / Bewegen / Wenden des Werkzeugs prüfen, dass der Tragbolzen korrekt montiert ist. Der Tragbolzen muss **UNBEDINGT** mit dem **Sicherheitsring** in Richtung der Werkzeugachse gerichtet montiert sein: Nach dem Einbringen muss sichergestellt werden, dass der Sicherheitsring ggü. dem Loch außermittig sitzt und der Tragbolzen nicht herausrutschen kann. Prüfen, ob sich der **Sicherheitsring bewegt** und die **Außermittigkeit "E"** gegenüber dem Tragbolzen prüfen (siehe Fig.2).

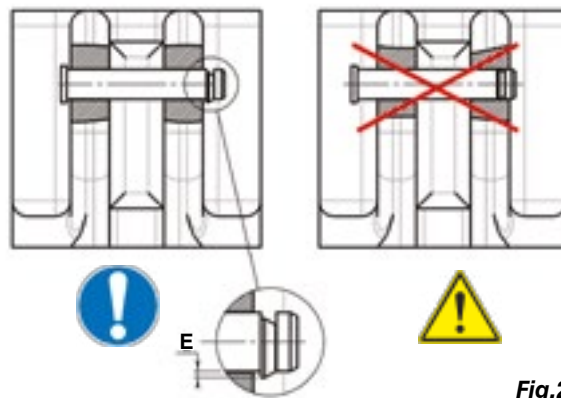

Fig.2

### 3.6

#### **⚠️ WARNUNG**



Es wird die Verwendung von Sperren empfohlen, um eine nicht korrekte Einbringung der Tragbolzen zu verhindern (siehe Fig.3).

SPERRE GEGEN DAS NICHT KORREKTE  
EINBRINGEN DES TRAGBOLZENS

WERKZEUGACHSE

EINBRINGRICHTUNG TRAGBOLZEN

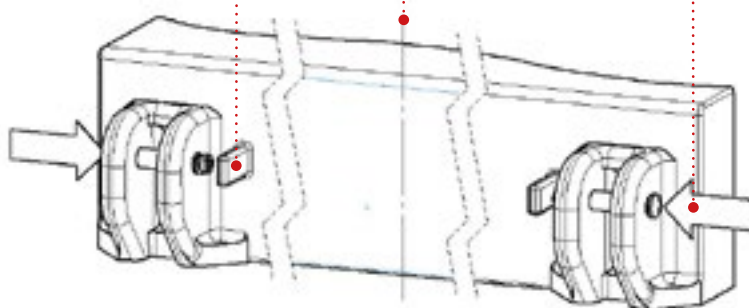

Fig.3

### 3.8

#### ⚠️ WARNUNG



Das Heben / Bewegen / Wenden nicht mit Anschlägen, die Winkel größer 90° ggü. der Horizontalen formen, durchführen, da ansonsten der Tragbolzen herausrutschen kann und das Risiko besteht, dass die Ladung fällt (siehe **Fig.4**).

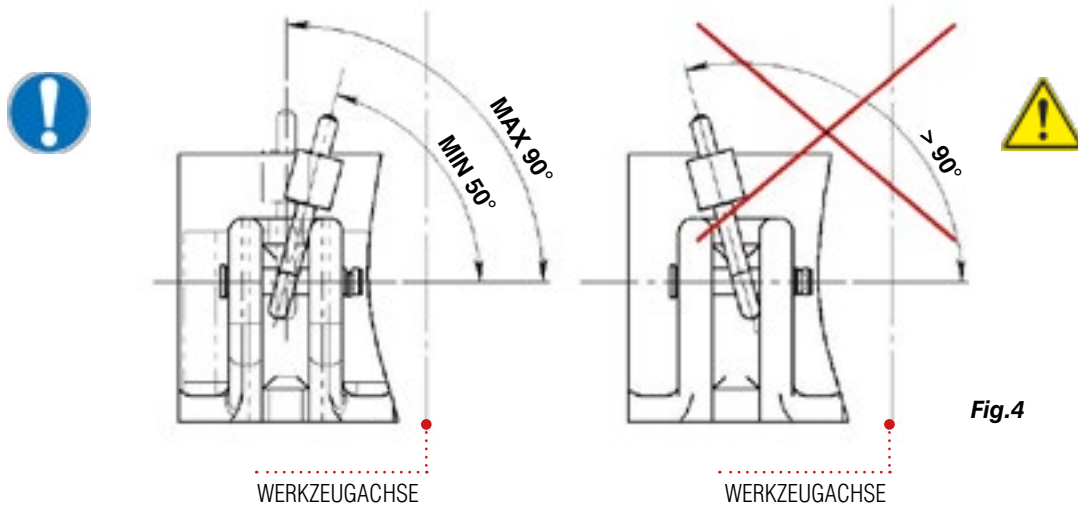

Fig.4

### 3.9

#### ⚠️ WARNUNG



Sich vor jedem Heben / Bewegen / Wenden des Werkzeugs versichern, dass:

- die Seile / Ketten korrekt gesichert sind,
- die Seile / Ketten nicht in Kontakt mit schneidenden Kanten sind und,
- die Seile / Ketten nicht in Kanten des Werkzeugs verhakt sind.

### 3.10

#### ⚠️ WARNUNG



Während dem Heben / Bewegen / Wenden (siehe **Fig.5**) darf man sich nicht in der Nähe der Ladung aufhalten.



Fig.5

## 4. TRANSPORT UND LAGERUNG

**4.1** Alle Tragbolzen der Fa. OMCR wiegen pro Stück weniger als 15 kg und können von Hand bewegt werden.

**4.2** Die Tragbolzen müssen an einem vor Feuchtigkeit geschützten Ort gelagert werden, wenn sie nicht in Gebrauch sind, und durch das Aufbringen von Schutzöl vor Oxidation geschützt werden.

## 5. INSTANDHALTUNG

**5.1** Alle 6 Monate Sichtkontrollen durchführen, um das Vorhandensein von sichtbaren Anomalien oder das Auftreten einer Oxidation zu prüfen: In diesem Fall den Originalzustand wieder herstellen oder die Tragbolzen austauschen.

**5.2** Mindestens alle 12 Monate eine Prüfung der Zylindrizität durchführen, um eventuelle permanente Deformationen (siehe **Fig.6**) auszuschließen: Bei Abweichungen, die größer als 0,25 mm sind, die jeweiligen Tragbolzen austauschen.

**5.3** Sollten die tragenden Seile / Ketten plötzlich reißen, mit daraus folgender Überbelastung der Tragbolzen, müssen diese auf Ihre Zylindrizität (siehe **Fig.6**) geprüft werden, um evtl. Deformationen auszuschließen. Bei Abweichungen, die größer als 0,25 mm sind, die jeweiligen Tragbolzen austauschen, die Befestigungsschrauben austauschen und prüfen, ob sie korrekt gemäß der Tabelle in dieser Betriebs- und Instandhaltungsanleitung angezogen sind.

**5.4** Nach unvorhergesehenen Stößen in den Anschlagbereichen während des Hebens/Bewegens/Wendens müssen die Tragbolzen auf Ihre Zylindrizität geprüft werden, um evtl. Deformationen auszuschließen. Bei Abweichungen, die größer als 0,25 mm (siehe **Fig.6**) sind, die jeweiligen Tragbolzen austauschen.



**Fig.6**



## CE-Konformitätserklärung

(Maschinenrichtlinie 2006/42/CE)

Die Firma OMCR S.r.l. mit Sitz in Via Quarantelli, 8 – 10077 S. Maurizio C.se – (Turin -Italien) erklärt in Person seines gesetzlichen Vertreters, dass die

### **TRAGBOLZEN MIT FALLRINGSICHERUNG**

#### **mit der Artikelnummer: B02.100**

auf jedem einzelnen Teil eine Produktionslos-Nummer geprägt haben, anhand der man jederzeit auf die in der technischen Abteilung archivierten Unterlagen zurückgreifen kann und somit jede Eigenschaft und jedes Produktions- und Prüfelement identifizieren kann.

Alle Qualitäts- und Sicherheitsverfahren wurden zusammengestellt von Herrn Bertorello, verantwortlich für die technischen Unterlagen, tätig bei OMCR Srl., Via Quarantelli 8, I-10077 San Maurizio C.se (TO). Sie wurden korrekt durchgeführt und dadurch wurde die

Berechtigung erlangt, das Schriftbild **CE** aufzuprägen, um zu garantieren, dass diese Teile:

- den in der Maschinenrichtlinie 2006/42/CE vom 09.06.2006 festgelegten Bedingungen entsprechen und
- Kontrollen und Prüfungen unterzogen worden sind, die belegen dass diese Produkte auch den harmonisierten und nationalen UNI Normen, den europäischen Richtlinien und den italienischen Vorschriften hinsichtlich der Arbeitssicherheit entsprechen.

*Vor dem Einsatz der Tragbolzen die Betriebs- und Instandhaltungsanleitung aufmerksam lesen.*

*Ein unsachgemäßer oder gegenteiliger Einsatz ggü. dem in der Anweisung beschriebenen Inhalt setzt die Gültigkeit dieser EG-Konformitätserklärung außer Kraft und enthebt die Firma OMCR von jeglicher Verantwortung diesbezüglich.*

*Diese Betriebs- und Instandhaltungsanleitung mit EG-Konformitätserklärung wurde aus dem Italienischen übersetzt, im Falle von Beanstandungen hat die italienische Version rechtliche Gültigkeit.*

**OMCR S.r.l.**  
der gesetzliche Vertreter  
Domenico Zentilin





Manual de uso y mantenimiento  
completo de declaracion **CE** de conformidad

# BULON DE ELEVACION

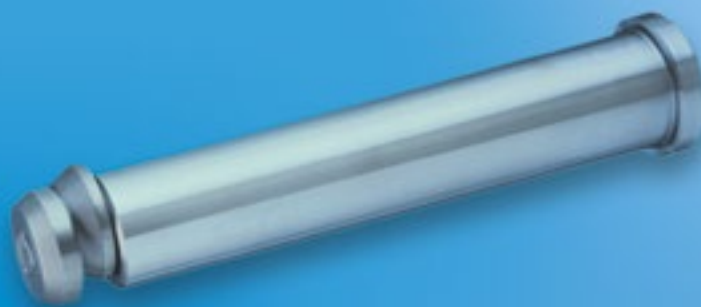

Codigos de articulo:  
**B02.100**

## ÍNDICE

1. VALORACION DE RIESGOS . . . . .	36
2. SIMBOLOGIA Y CLASIFICACION DE LAS ADVERTENCIAS . . . . .	36
3. UTILIZATION . . . . .	37
4. MANUTENCION Y ALMACENAMIENTO . . . . .	43
5. MANTENIMIENTO . . . . .	43
DECLARATION CE DE CONFORMIDAD. . . . .	44

## 1. VALORACION DE RIESGOS

El contenido de las siguientes páginas hace referencia al uso habitual de los dispositivos de elevación lateral con bulón, y no puede prever usos no específicos. Por esta razón cada usuario debe tener en cuenta su propia valoración de riesgos, y utilizar este manual como referencia general, considerando la necesidad de síntesis de sus argumentos. Es competencia y responsabilidad del usuario definir a los operarios los procedimientos de uso, verificar su cumplimiento y facilitarles información.



Los dispositivos de elevación lateral con bulón funcionan con un gancho para eslinga o cadena, y permiten efectuar con seguridad operaciones de: TRANSPORTE / DESPLAZAMIENTO; el material, fabricación y control de calidad de todos los bulones de transporte OMCR son conformes a la directiva **2006/42/CE**; todos los elementos de transporte OMCR son verificados con un coeficiente de prueba estática mínimo de 1.5. Son efectuados análisis sobre todos los materiales según **UNI EN 10204**, sobre las muestras se hacen pruebas de tracción convencional conforme a **UNI EM 10002**. **Los cálculos y valoración de riesgos son conformes a la normativa de BMW, FCA, FORD, MERCEDES-BENZ, OPEL, PSA, RENAULT, VOLVO, VW-AUDI, VDI3366.**

### **ADVERTENCIA**

**Antes de utilizar los pasadores de elevación leer con cuidado este manual de uso y mantenimiento. Un uso impropio o contrario a lo indicado en este manual exime a OMCR de cualquier responsabilidad sobre la seguridad de de los elementos citados.**

## 2. SIMBOLOGIA Y CLASIFICACION DE LAS ADVERTENCIAS

Según las normativas ISO 3864-2, ANSI Z535.6, ANSI Z535.4, en este manual se han clasificado los siguientes mensajes de seguridad y sus símbolos:

 <b>ADVERTENCIA</b>	Indica una situación potencialmente peligrosa que de no evitarse puede provocar daños importantes o la muerte.
 <b>ATENCIÓN</b>	Indica una situación potencialmente peligrosa que de no evitarse puede provocar lesiones leves o moderadas.
<b>NOTA</b>	Indica sugerencias u otras informaciones de especial importancia
	Indica un peligro genérico.
	Indica un riesgo de aplastamiento como consecuencia de caída o vuelco de la carga.
	Indica riesgo de cizallamiento como consecuencia de la caída o vuelco de la carga.
	Indica un riesgo músculo-esquelético como consecuencia del manejo manual de la carga.
	Indica operaciones o modos de uso prohibidos.
	Indica acciones a efectuar para evitar riesgos.
	Indica la prohibición de detenerse o transitar.

### 3. UTILIZATION

#### 3.1

#### ⚠ ADVERTENCIA



Cada operación de transporte / desplazamiento / volteo tiene que ser efectuada por personal cualificado y debidamente formado; los encargados del transporte, desplazamiento, volteo deben usar los medios de protección individual adecuados.

#### 3.2

#### ⚠ ADVERTENCIA



Antes de cada operación de transporte / desplazamiento / volteo los operarios deben elegir el anclaje idóneo para garantizar una suspensión segura con un correcto equilibrio de la carga. La carga efectiva de las eslingas / cadenas y de los accesorios de transporte puede ser alterada por el uso de un anclaje incorrecto. La siguiente tabla permite valorar la reducción de la carga nominal en función del ángulo del anclaje de seguridad con el fin de mantener constante el factor de seguridad.

#### NOTE

Para la definición de arneses simétricos o asimétricos ver norma EN818-06: en caso de arneses asimétricos, se considera que el peso a levantar sea soportado por sólo dos brazos de cuerda o cadena.

#### 3.2.1 - ELEVACION

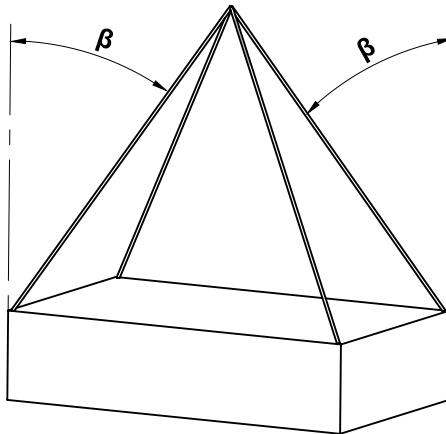

#### EJEMPLO DE ARNESES SIMETRICOS (CONDICION ACONSEJADA)

ANGULO	FACTOR DE REDUCCION DE CARGA DE LA OREJETA
$0^\circ \leq \beta \leq 40^\circ$	1
$40^\circ < \beta \leq 50^\circ$	0.84
$50^\circ < \beta \leq 60^\circ$	0.65

**G** = Centro de gravedad del troquel

**β** = Ángulo de las cuerdas/cadenas desde la vertical

**NOTA:** la elevación con  $\beta > 60^\circ$  no está prevista

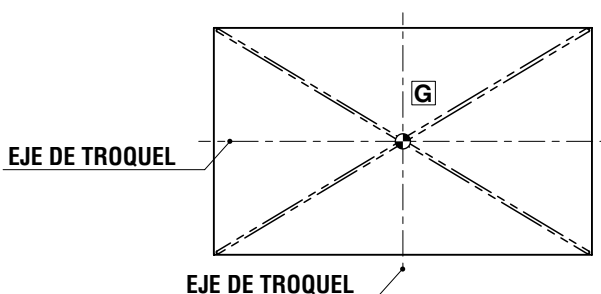

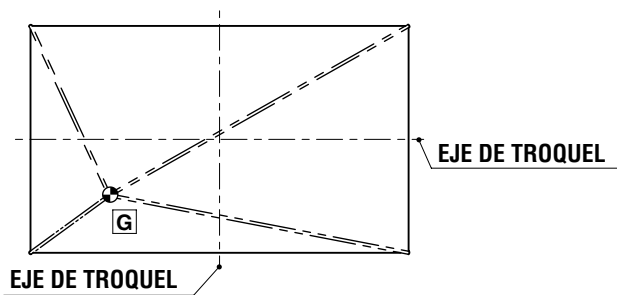
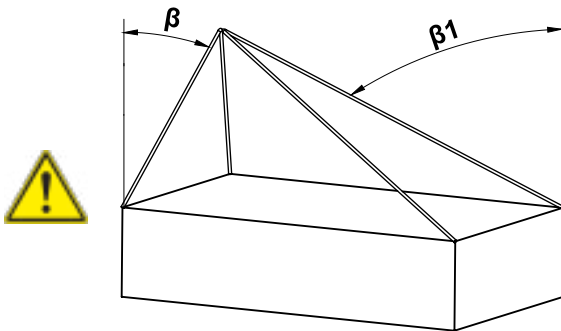

### EJEMPLO DE ARNESES ASIMETRICOS

#### FACTOR DE REDUCCION DE CARGA DE LA OREJETA

0.5

**G** = Centro de gravedad del troquel

**β** = Ángulo de la cuerda/cadena mínimo desde la vertical

**β1** = Ángulo de la cuerda/cadena máximo desde la vertical

### ADVERTENCIA

*El no cumplimiento de las prescripciones contenidas en el presente manual puede provocar riesgo de caída accidental de la carga.*

### 3.2.2 - VOLTEO

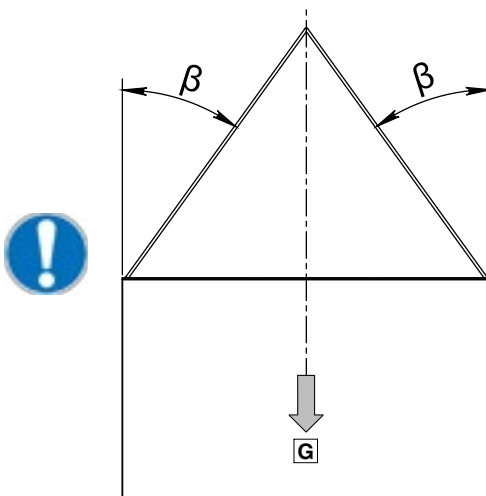

### EJEMPLO DE ARNESES SIMETRICOS (CONDICION ACONSEJADA)

ANGULO	FACTOR DE REDUCCION DE CARGA DE LA OREJETA
$0^\circ \leq \beta \leq 40^\circ$	1
$40^\circ < \beta \leq 50^\circ$	0.84
$50^\circ < \beta \leq 60^\circ$	0.65

**G** = Centro de gravedad del troquel

**β** = Ángulo de las cuerdas/cadenas desde la vertical

**NOTA:** la elevación con  $\beta > 60^\circ$  no está prevista

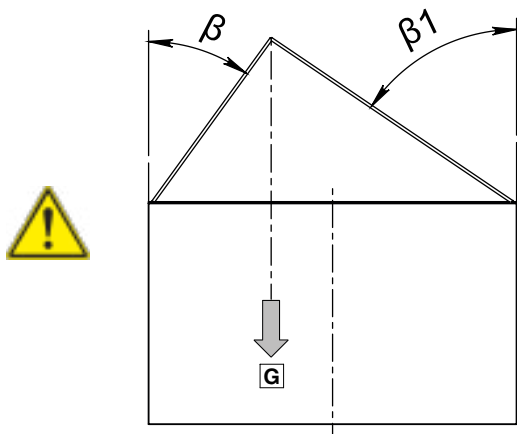

**EJEMPLO DE ARNESES ASIMÉTRICAS**  
( $\beta_1 > \beta$ )

ANGULO	FACTOR DE REDUCCION DE CARGA DE LA OREJETA
$\beta < 15^\circ$	0.5
$\beta > 40^\circ$	
$\beta_1 - \beta > 15^\circ$	

**G** = Centro de gravedad del troquel

**β** = Ángulo de la cuerda/cadena mínimo desde la vertical

**β1** = Ángulo de la cuerda/cadena máximo desde la vertical

**⚠ ADVERTENCIA**

*El no cumplimiento de las prescripciones contenidas en el presente manual puede provocar riesgo de caída accidental de la carga.*

**3.2.3**

**⚠ ADVERTENCIA**



*El volteo del troquel debe efectuarse sólo en paralelo al eje del bulón de transporte.*

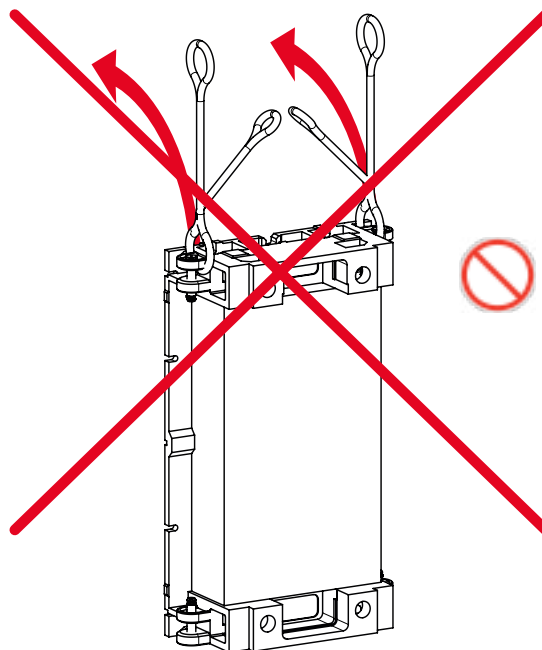
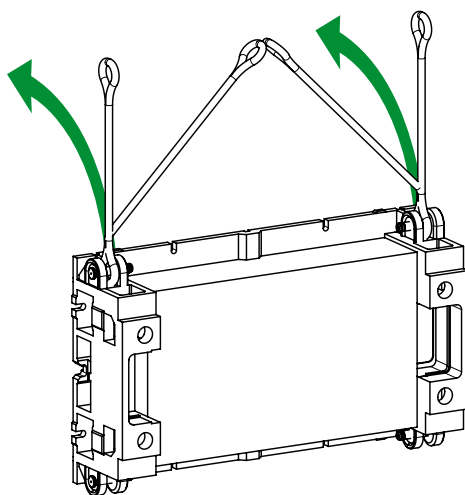

### 3.3

#### **⚠ ADVERTENCIA**



Antes de cualquier elevación / desplazamiento / volteo verificar que la capacidad de carga de los bulon se apropiada para el peso del troquel; la carga máxima, la orden de fabricación, el logo del fabricante, el sello de conformidad CE, el código de artículo y el material son marcados de modo indeleble en el bulón (ver **Fig.1**).

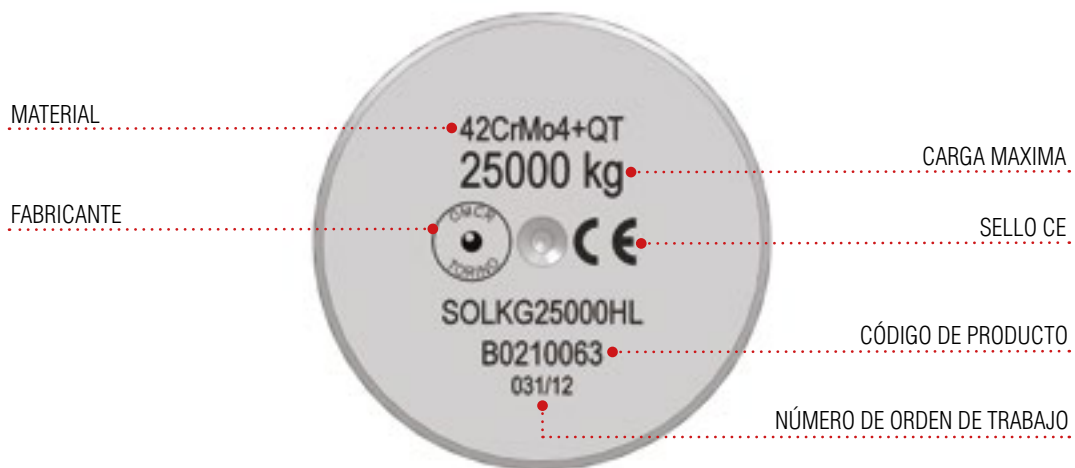

**Fig.1**

La carga del dispositivo de elevación no debe ser inferior a **1/2** del peso total del troquel en el caso de transporte y desplazamiento.

Ej: Peso del torquel 25.000 kg

Carga mínima del dispositivo de elevación:  $25.000 / 2 = 12.500$  kg

La carga del dispositivo de elevación no debe ser en absoluto inferior al peso del semitroquel en el caso de volteo.

Ej: Peso del torquel 12.500 kg

Carga mínima del dispositivo de elevación:  $12.500 / 2 = 6.250$  kg

### 3.4

#### **⚠ ADVERTENCIA**



Antes de cada transporte / desplazamiento / volteo del troquel verificar que el anclaje elegido (eslinga / cadena, gancho, etc.) no presente defectos o fallos que puedan volverlo inseguro; en tal caso eliminar inmediatamente las partes defectuosas.



### 3.5

#### **⚠ ADVERTENCIA**



Antes de cada transporte/desplazamiento/volteo del troquel asegurarse del correcto posicionamiento del bulón de transporte que debe **IMPERATIVAMENTE** ser montado con el **anillo de seguridad** vuelto hacia el eje del troquel: después de haberlo introducido verificar que el **anillo de seguridad** sea desplazado de su eje respecto al agujero e impida la extracción del bulón; verificar el movimiento del **anillo de seguridad** comprobando la excentricidad "E" respecto del bulón (ver **Fig.2**)

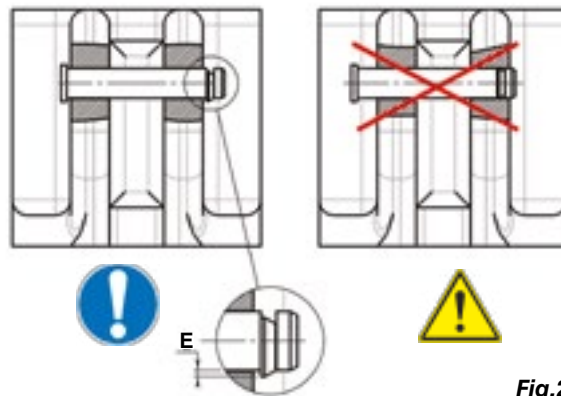

Fig.2

### 3.6

#### **⚠ ADVERTENCIA**



Recomendamos el uso de barreras para evitar la inserción incorrecta de los bulones (ver **Fig.3**).

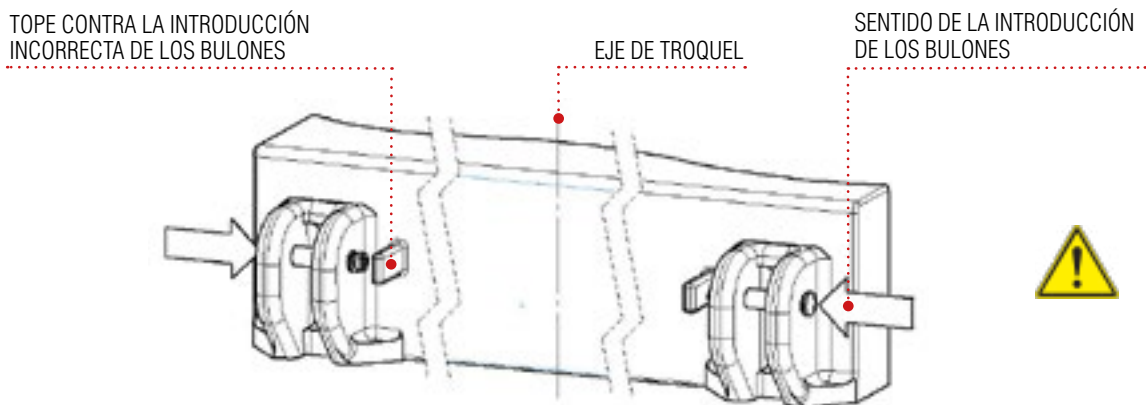

Fig.3

3.8

**ADVERTENCIA**



No efectuar transporte / desplazamiento / volteo con anclajes con ángulos superiores a 90° respecto a la horizontal, en caso contrario se puede producir la extracción del bulón con riesgo de caída de la carga (ver: **Fig.4**).

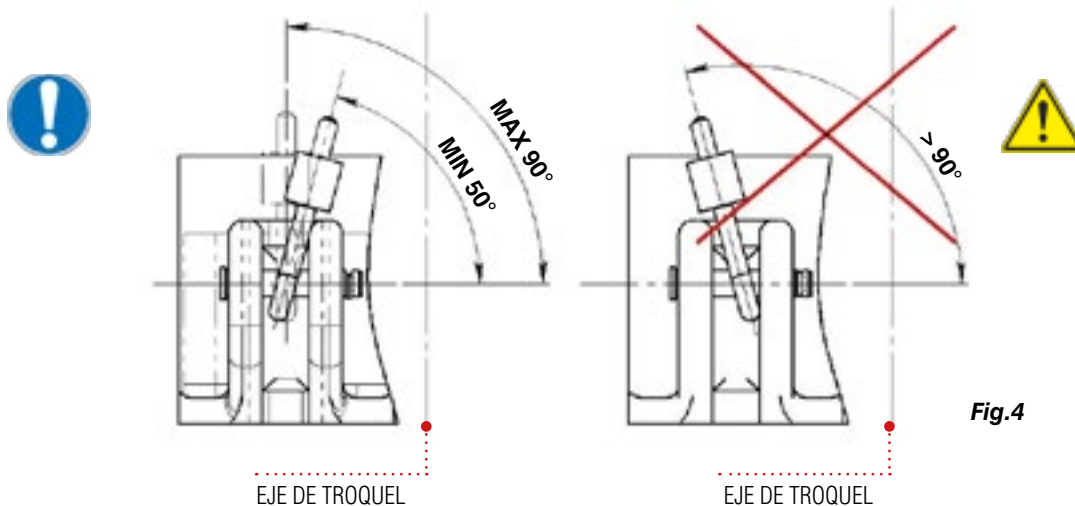

Fig.4

3.9

**ADVERTENCIA**



Antes de cada transporte / desplazamiento / volteo del troquel asegurarse de que:

- las eslingas/cadenas estén correctamente aseguradas;
- las eslingas/cadenas no estén en contacto con zonas cortantes;
- las eslingas/cadenas no se enganchen en las esquinas del troquel.

3.10

**ADVERTENCIA**



No permanecer cerca de la carga durante las operaciones de transporte / desplazamiento / volteo (ver **Fig.5**). **En caso de enganche accidental de la carga puede haber riesgo de lesión.**



Fig.5

## 4. MANUTENCION Y ALMACENAMIENTO

- 4.1** Todos los bulones de transporte de OMCR tienen un peso unitario inferior a 15 kg y pueden ser manejados a mano.
- 4.2** Los bulones de elevación deben ser almacenados en un lugar libre de humedad en caso de no utilización, y protegidos de la oxidación aplicando un aceite protector.

## 5. MANTENIMIENTO

- 5.1** Efectuar cada 6 meses controles visuales para verificar la presencia de anomalías visibles o apariciones de oxidación: en ese caso, reponer o sustituir los bulones afectados.
- 5.2** Efectuar al menos cada 12 meses un control de cilindridad para verificar eventuales deformaciones permanentes (ver **Fig.6**); en el caso de errores superiores a 0,25 mm sustituir los bulones afectados.
- 5.3** En el caso de que se verifique que las eslingas/cadenas han cedido, con la consiguiente sobrecarga de los bulones de transporte, someterlos a controles de cilindridad (ver **Fig.6**) para verificar eventuales deformaciones; en el caso de errores superiores a 0,25 mm sustituir los bulones afectado.
- 5.4** En el caso de golpes accidentales en la zona de anclaje durante las operaciones de transporte, desplazamiento y volteo, someter a los bulones a controles de cilindridad para verificar eventuales deformaciones; en caso de errores superiores a 0,25 mm sustituir los bulones afectados.

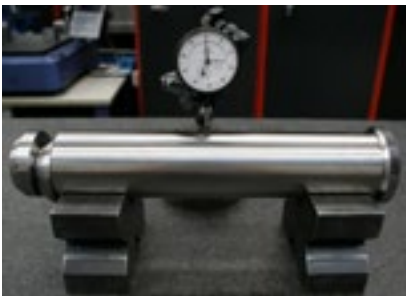

**Fig.6**

# DECLARATION CÉ DE CONFORMIDAD

(Directiva Maquinaria 2006/42/CE )

Die Firma OMCR S.r.l. mit Sitz in Via Quarantelli, 8 – 10077 S. Maurizio C.se – (Turin -Italien) erklärt in Person seines gesetzlichen Vertreters, dass die

## **BULONES DE TRANSPORTE**

### **Código de producto: B02.100**

Tienen un número de orden de fabricación estampado en cada pieza, desde el cual, en cualquier momento, se puede llegar a la documentación archivada en la Oficina Técnica y así identificar cada característica y elemento de fabricación y control de calidad. Todos los procedimientos de calidad y seguridad, dispuestos por el sr.Bertorello, responsable del dossier técnico y empleado en la sede de OMCR en Via Quarantelli 8, 10077 San Maurizio C.se, han sido correctamente ejecutados y esto nos ha permitido el marcaje del símbolo CÉ para garantizar que los siguientes elementos:



- Son conformes a las condiciones indicadas por la directiva Maquinaria 2006/42/CE del 9.6.2006.
- Son objeto de control y verificación, para adecuarse también a las normas UNI, las directivas europeas y las disposiciones italianas sobre seguridad laboral.

*Antes de la utilización de los dispositivos de elevación lateral con bulón leer atentamente el manual de uso y mantenimiento*

*Una utilización impropia o contraria a la descrita en el manual, anula la validez de la presente declaración CE de conformidad y exime a OMCR de cualquier responsabilidad.*

*Este manual de uso y mantenimiento completo conforme a la normativa CE ha sido traducido del italiano, en el caso de cualquier reclamación tiene validez jurídica la versión en italiano.*

**OMCR S.r.l.**  
**El representante legal**  
**Domenico Zentilin**



Notice d'entretien et d'usage  
avec déclaration **CE** de conformité.

# BROCHE DE MANUTENTION

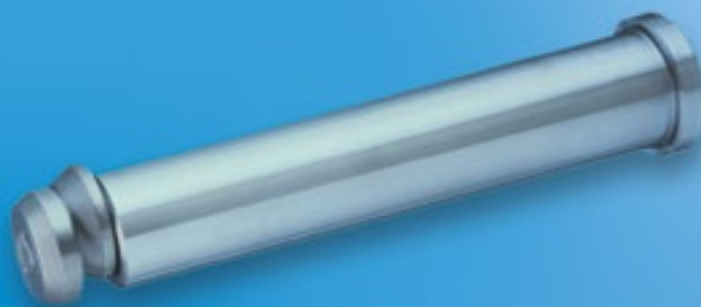

Code de l'article:  
**B02.100**

## INDEX

1. ÉVALUATION DES RISQUES. ....	47
2. SYMBOLIQUE ET CLASSIFICATION DES AVERTISSEMENTS. ....	47
3. USAGE .....	48
4. MOUVEMENTATION ET STOCKAGE .....	54
5. ENTRETIEN .....	54
DÉCLARATION CE DE CONFORMITÉ .....	55

## 1. ÉVALUATION DES RISQUES

Les contenus des pages suivantes se réfèrent au usage classiques des broches de manutention et ils peuvent pas prévoir emplois pas-spécifiques. Pour cette raison, chacun utilisateur doit pourvoir une propre évaluation des risques et il doit prendre en compte cette notice comme référence générale en considérant la nécessité de synthèse dans traiter les sujets. C'est à l'utilisateur de définir les procédures d'emploi concernant les opérations à suivre pour le personnel préposé, il doit aussi diffuser les informations et vérifier en le respect. Les broches de manutention servissent comme crochet pour cordes ou chaînes et ils permettent d'effectuer en sécurité les opérations de: LEVAGE, MOUVEMENTATION, RENVERSMENT; le matériel, la production et l'essai de tous les chapes de manutention OMCR sont conformes aux requêtes de la Directive **2006/42/CE**; tous les éléments de manutention OMCR viennent vérifiés avec un coefficient d'épreuve statique égal au minimum 1.5, sur tous les matériels viennent effectuées analyses selon l'**UNI EN 10204**, sur échantillons viennent effectuées épreuves à traction conventionnelle conformes au **UNI EN 10002**. **Les calculs et les évaluations des risques sont conformes aux normes BMW, FCA, FORD, MERCEDES-BENZ, OPEL, PSA, RENAULT, VOLVO, VW-AUDI, VDI3366.**

### **AVVERTISSEMENT**

**Avant l'usage des broches de manutention, lire attentivement la notice d'usage et d'entretien.  
Un usage impropre ou contraire en référence à ceci qu' est écrit dans la notice, décharge l'OMCR de  
quelconque responsabilités concernant la sécurité des sujets cités.**

## 2. SYMBOLIQUE ET CLASSIFICATION DES AVVERTISSEMENTS

Dans cette documentation la classification des dangers a été fait en référence aux normes ISO 3864-2, ANSI Z535.6, ANSIZ535.4, comme suit:

 <b>AVVERTISSEMENT</b>	Désigne une situation potentiellement dangereuse. Si cette situation dangereuse ne peut pas être évitée, la mort ou des blessures graves (mutilations) peuvent en être la conséquence.
 <b>ATTENTION</b>	Désigne une situation potentiellement dangereuse. Si cette situation dangereuse ne peut pas être évitée, des blessures légères ou minimales peuvent en être la conséquence.
<b>NOTE</b>	Conseils ou autres informations d'une importance particulière.
	Danger générique.
	Risque d' écrasement suite la chute ou le renversement du charge.
	Risque de cisaillement suite la chute ou le renversement du charge.
	Risque des troubles musculo-squelettiques pour la mouvementation manuelle des charges.
	Opérations ou emplois pour un usage interdit.
	Mesures à prendre pour éviter les risques.
	Stationnement ou passage interdit.

### 3. USAGE

#### 3.1

##### ⚠ AVERTISSEMENT



Chaque opérations de levage / mouvementation / renversement doit être exécutées par un personnel qualifié et appropriément instruit; les personnes préposées au levage, mouvementation, renversement doivent utiliser moyens de protection en dotation.

#### 3.2

##### ⚠ AVERTISSEMENT



Avant chaque levage / mouvementation / renversement les personnes préposées doivent choisir l'élingue plus appropriée à garantir une suspension en sécurité avec un correct équilibre du charge. L'effective portée des cordes / chaînes et des accessoires de manutention peut être modifié par un élingue incorrecte. Dans le tableau suivant on peut évaluer la réduction de la portée nominale en fonction de l'angle de l'élingue au but de maintenir constant le facteur de sécurité.

##### NOTE

Pour la définition des élingues symétriques et asymétriques vous devez voir la norme EN818-06: en cas des élingues asymétriques, on considère que le charge à soulever est supporté par seulement deux bras de corde/chaîne.

#### 3.2.1 - LEVAGE

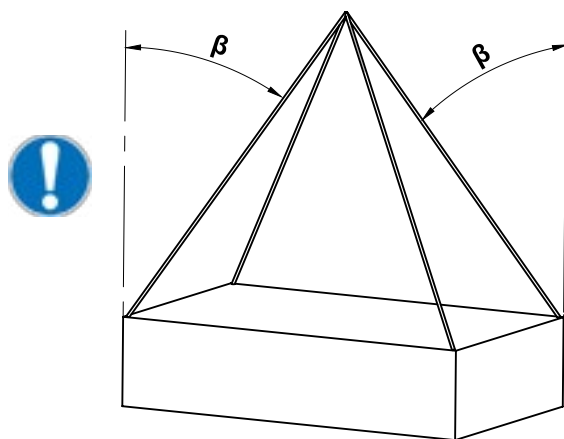

##### EXEMPLE DES ÉLINGUES SYMÉTRIQUES (CONDITION RECOMMANDÉE)

ANGLE	FACTEUR DE RÉDUCTION DE LA PORTÉE DE LA BROCHE
$0^\circ \leq \beta \leq 40^\circ$	1
$40^\circ < \beta \leq 50^\circ$	0.84
$50^\circ < \beta \leq 60^\circ$	0.65

**G** = Barycentre outillage

**β** = Angle des cordes à partir de la verticale

**NOTE:** le levage avec  $\beta > 60^\circ$  il est pas prévu

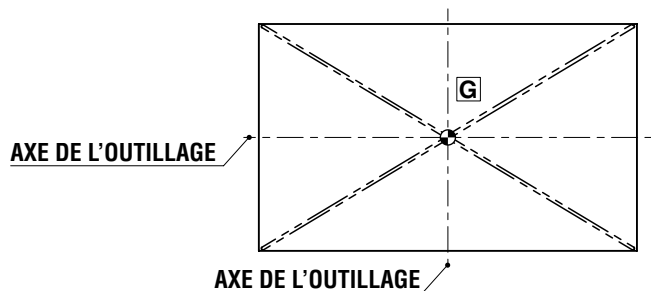



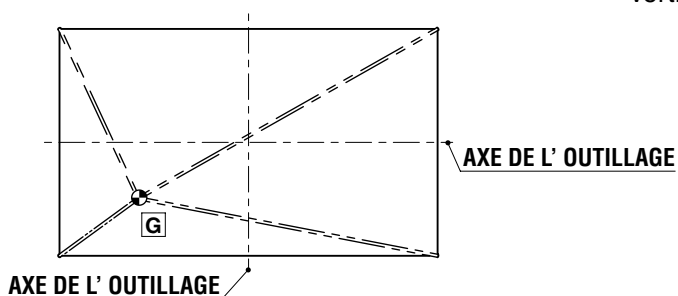
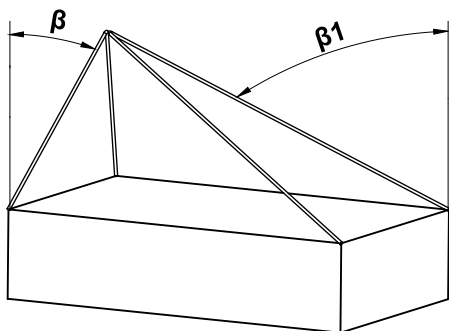

### EXEMPLE DES ÉLINGUES ASYMÉTRIQUES

#### FACTEUR DE RÉDUCTION DE LA PORTÉE DE LA BROCHE

0.5

**G** = Barycentre outillage

**β** = Angle minimal des cordes à partir de la verticale

**β1** = Angle maximal des cordes à partir de la verticale



### AVERTISSEMENT

*Le non-respect des prescriptions contenues dans la présente notice peut provoquer la chute ou le renversement du charge.*

### 3.2.2 - RENVERSEMENT

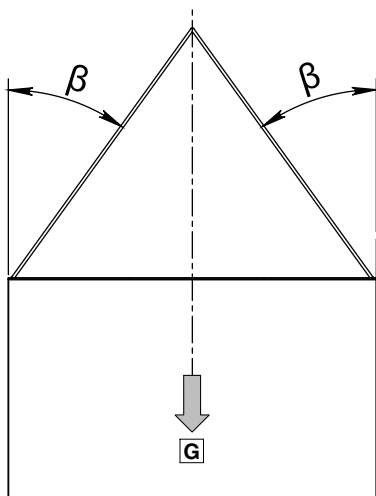

### EXEMPLE DES ÉLINGUES SYMÉTRIQUES (CONDITION RECOMMANDÉE)

ANGLE	FACTEUR DE RÉDUCTION DE LA PORTÉE DE LA BROCHE
$0^\circ \leq \beta \leq 40^\circ$	1
$40^\circ < \beta \leq 50^\circ$	0.84
$50^\circ < \beta \leq 60^\circ$	0.65

**G** = Barycentre outillage

**β** = Angle des cordes à partir de la verticale

**NOTE:** le levage avec  $\beta > 60^\circ$  il est pas prévu

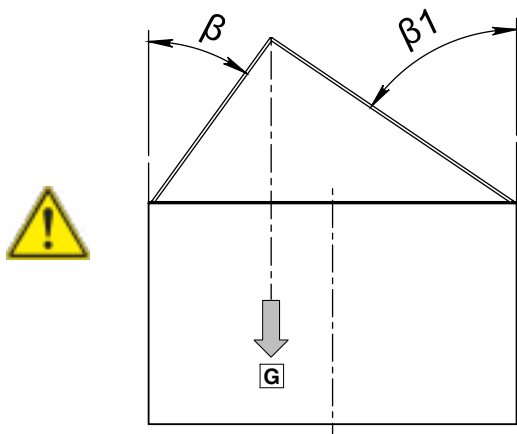

**EXEMPLE DES ÉLINGUES ASYMÉTRIQUES**  
( $\beta_1 > \beta$ )

ANGLE	FACTEUR DE RÉDUCTION DE LA PORTÉE DE LA BROCHE
$\beta < 15^\circ$	0.5
$\beta > 40^\circ$	
$\beta_1 - \beta > 15^\circ$	

**G** = Barycentre outillage

**$\beta$**  = Angle minimal des cordes à partir de la verticale

**$\beta_1$**  = Angle maximal des cordes à partir de la verticale

**⚠ AVERTISSEMENT**

*Le non-respect des prescriptions contenues dans la présente notice peut provoquer la chute ou le renversement du charge.*

**3.2.3**

**⚠ AVERTISSEMENT**



*Le renversement de l'outillage peut être exécuté seulement parallèlement à l'axe de la broche de manutention.*

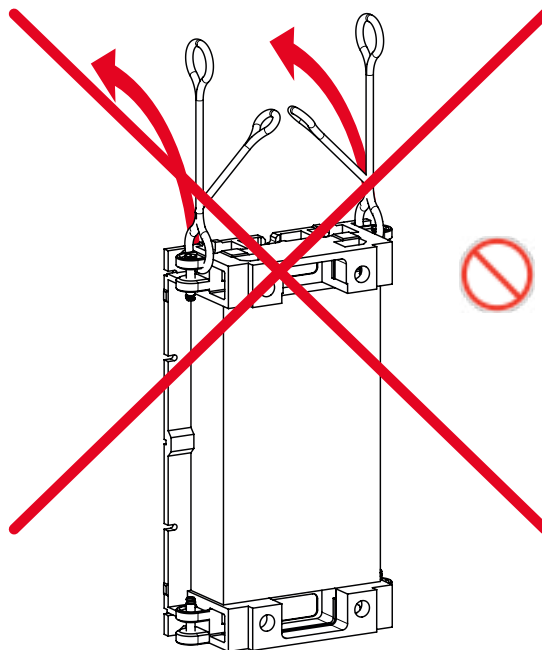
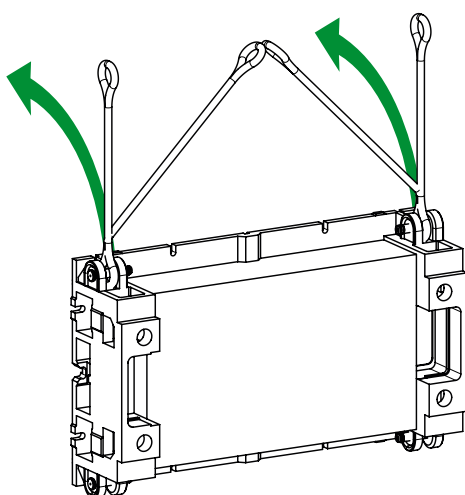

### 3.3

#### **AVVERTISSEMENT**



Avant chaque levage / mouvementation / renversement vérifier que la portée des chapes de manutention est conforme au poids de l'outillage la portée maximal, la commande de fabrication, le logo du constructeur et le marque de conformité CE, sont marqués sur la chape de manutention et sur la broche (**Fig.1**)

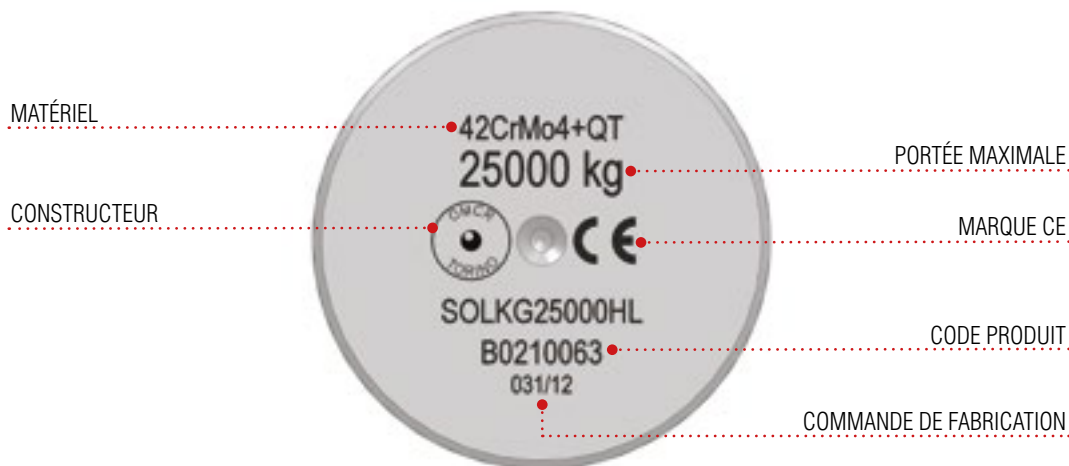

**Fig.1**

En cas de levage et manipulation la portée de la broche de manutention doit être au moins égal à **1/2** du poids total de l'outillage (demi-outillage supérieur + demi-outillage inférieur)

Exemple: poids outillage 25.000 kg - portée minimale de la broche:  $25.000 / 2 = 12.500$  kg

En cas de renversement d'un demi-outillage, la portée de la broche de manutention doit être au moins égal à **1/2** du poids du demi-outillage.

Exemple: poids demi-outillage 12.500 kg - portée minimale de la broche =  $12.500 / 2 = 6.250$  kg

### 3.4

#### **AVVERTISSEMENT**



Avant chaque levage / mouvementation / renversement vérifier que l'élingue choisi (corde / chaîne, crichets, etc.) n'a pas défauts ou malformations qui lui rendent pas en sécurité; dans le cas **éliminer tout de suite les parties défectueuses**.

### 3.5

#### ⚠ AVERTISSEMENT



Avant chaque levage / mouvementation / renversement de l'outillage s'assurer de la correct insertion de la broche du manutention que doit **FORMELLEMENT** être monté avec la **came de sécurité** vers l'axe de l'outillage: après l'avoir inséré, s'assurer que la **came de sécurité** est pas en axe en respect au trou et elle empêche le désenfillement de la broche; vérifier le mouvement de la **came de sécurité** en vérifiant l'excentricité "E" respect à la broche (voir Fig.2)

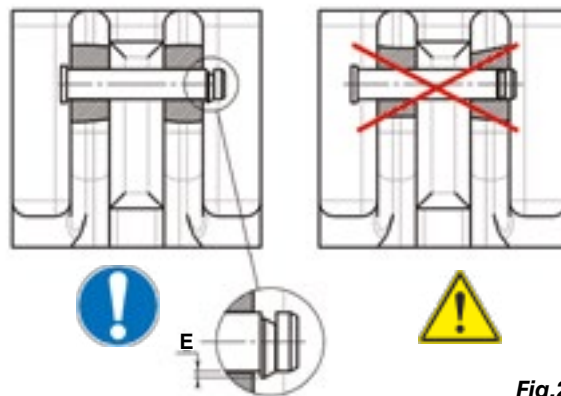

Fig.2

### 3.6

#### ⚠ AVERTISSEMENT



On conseille l'usage des barrières à éviter l'insertion incorrecte des broches (voir Fig.3)

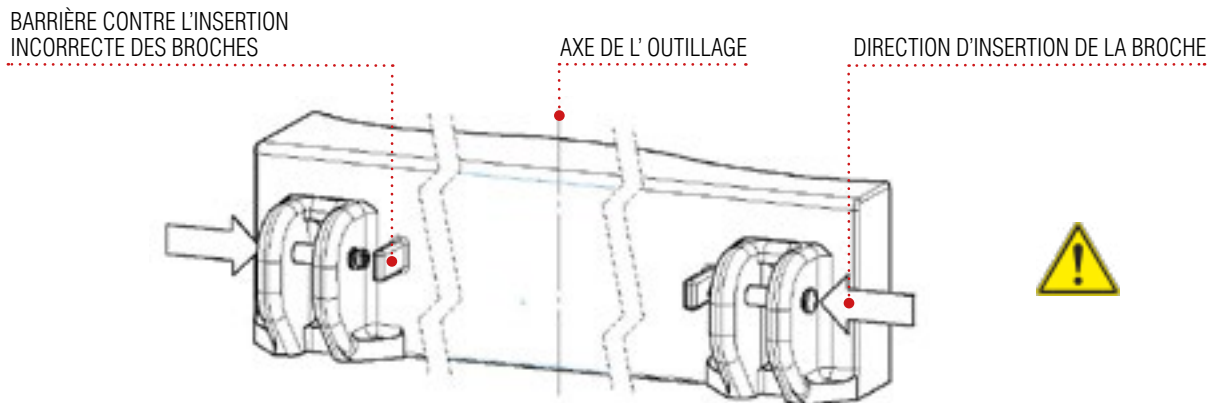

Fig.3

3.8

**AVERTISSEMENT**



Pas effectuer levage / mouvementation / renversement avec élingue que forme angles supérieurs à 90° en respect au plan horizontal , en cas contraire on peut se vérifier désenfillement de la broche avec le risque de la chute du charge (voir Fig.4).

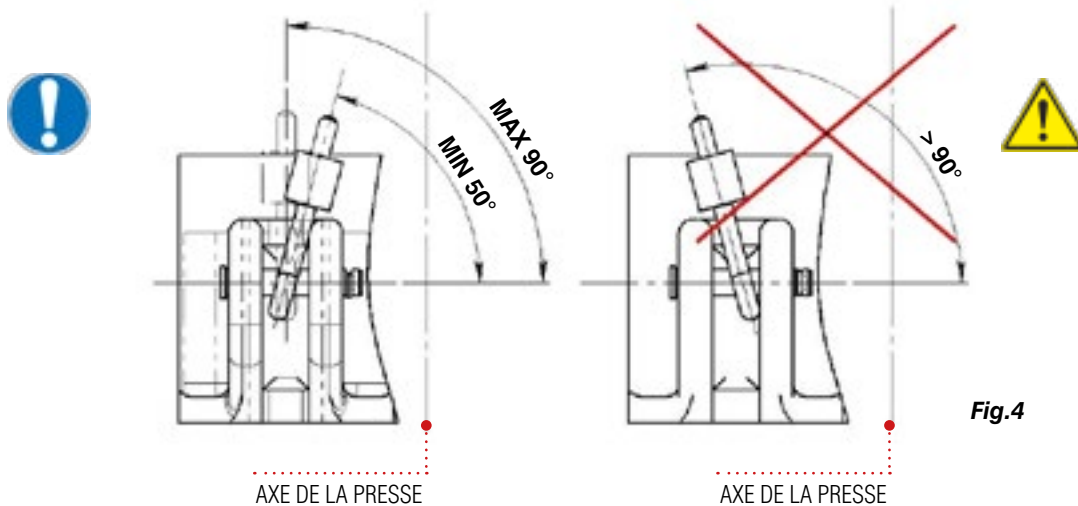

Fig.4

3.9

**AVERTISSEMENT**



Avant chaque levage / mouvementation / renversement du moule s'assurer que :

- les cordes/chaînes sont assurées dans une correcte façon;
- les cordes/chaînes sont pas en contact avec bords tranchants;
- les cordes/chaînes sont pas accrochées dans les coins de l'outillage.

3.10

**AVERTISSEMENT**



Pas s'arrêter ou transiter près du charge pendant les opérations de levage / mouvementation / renversement (voir Fig.5).



Fig.5

## 4. MOUVEMENTATION ET STOCKAGE

**4.1** Tous les broches de manutention OMCR ont un poids unitaire inférieur à 15 kg et ils peuvent être movimentés à main.

**4.2** Les broches de manutention doivent être stockées dans lieux loins de l'humidité, si pas utilisées, et protégées de l'oxydation en appliquant huile protectif.

## 5. ENTRETIEN

**5.1** Effectuer tous les 6 mois contrôles visuels pour vérifier la présence des anomalies visibles ou apparition d'oxydation: en cas rétablir ou remplacer les broches intéressées.

**5.2** Effectuer au moins tous les 12 mois un contrôle de cylindricité pour vérifier eventuelles déformations permanentes (voir **Fig.6**): en cas des erreurs supérieurs à 0,25 mm remplacer les broches intéressés.

**5.3** En cas des imprévus effondrements des cordes / chaînes de levage avec un conséquent surcharge sur les broches de manutention, soumettre ceux-ci au contrôle de cylindricité (voir **Fig.6**) pour vérifier eventuelles déformations; en cas des erreurs supérieurs à 0,25 mm remplacer les broches intéressés.

**5.4** En cas de collisions accidentelles dans le zones d' élingue pendant les opérations de levage / mouvementation / renversement, soumettre ceux-ci au contrôle de cylindricité pour vérifier eventuelles déformations; en cas des erreurs supérieurs à 0,25 mm (voir **Fig.6**) remplacer les broches intéressés;



**Fig.6**

# DÉCLARATION CÉ DE CONFORMITÉ

(Directive Machine 2006/42/CE)

L'OMCR S.r.l. avec siège en Via Quarantelli, 8 – 10077 S.Maurizio C.se – (Torino-Italia) dans la personne de son représentant juridique, déclare que, les:

## **BROCHE DE MANUTENTION**

### **Code de l'article: B02.100**

Ils ont un nombre du commande de fabrication marqué sur chacun exemplaire dont, en quelconque moment, on peut remonter à la documentation archivée près le Bureau Technique et donc identifier chaque caractéristique et élément de production et essai.

Toutes les procédures, de qualité et de sécurité, préparées par Mounsier Bertorello, responsable du dossier technique, en action dans la siège de OMCR,

Via Quarantelli,8 10077 San Maurizio C.se, ont été correctement exécutées et ce-ci a permit l'estampillage du symbole **CÉ** à garantir que ces pièces:



- *sont conformes aux conditions fixées par la Directive Machine 2006/42/CE du 9.6.2006*
- *Sont soumis aux contrôles et vérifications, tels à considerer ceux aptes aussi pour le normes UNI harmonisées et nationales, les directives Européennes et les dispositions italiennes sur la sécurité du travail.*

*Avant l'usage des chapes de manutention, lire attentivement la notice d'usage et d'entretien.*

*Un usage impropre ou contraire en référence à ceci qu' est écrit dans la notice, révoque la validité de cette présente déclaration CE de conformité et décharge l' OMCR de quelconque responsabilités à propos.*

*Traduction de l'originelle Notice d'Usage et Entretien et de la Déclaration de Conformité. En cas de doutes ou incompréhensions, la version Italienne est décisive.*

**OMCR S.r.l.**  
Le représentant légal  
Domenico Zentilin

